

Number	N.84
Section	Body
Page	1 of 2
Date	November, 1971.

BONNET MASCOT

Models affected

2.4 / 3.4 litre Mark 1
2.4 / 3.4 / 3.8 litre Mark 2
3.4 / 3.8 litre 'S' type

Difficulties in manufacturing Bonnet Mascot BD.10954 have resulted in it being withdrawn and supplies are no longer available. Orders for replacements for the above cars will therefore be executed by Jaguar Spares Division supplying an alternative Bonnet Mascot BD.29644 which varies from the original by the positions of the mounting studs. Instructions for the installation of the new Mascot are therefore detailed below.

INSTALLATION INSTRUCTIONS FOR BONNET MASCOT BD.29644

If the original Bonnet Mascot, part number BD.10954, is replaced by Mascot part number BD.29644, the following instructions should be carefully followed:-

1. Remove original Mascot from bonnet
2. Remove front and rear portion of bonnet centre beading
3. Retouch paintwork (if necessary) where bonnet is affected by contact with Mascot or chrome beading.
4. Lightly mark centre line through existing fixing holes, extending line forward by 2 in. (50 mm.).
5. Drill 3/16 in. (4.8 mm.) hole 'A' on centre line, 1 3/8 in. (35 mm.) to rear of front Mascot fixing hole. Locate new Mascot in holes
6. Place rear chrome bead in position, mark against rear of new Mascot base. Remove chrome bead and carefully cut to length. Clean up end of bead.
7. Place front chrome bead in position, mark against front of new Mascot base. Remove chrome bead and carefully cut to length. Clean up end of bead.

8. Lightly mark bonnet across front of new Mascot base.
9. Remove Mascot and centre pop bonnet $\frac{1}{2}$ in. (12.7 mm.) forward of mark. Drill $\frac{1}{8}$ in. (3.17 mm.) diameter hole 'B' in bonnet.
10. Locate clip BD.11719 and secure to bonnet, using pop rivet BD.1814/6
11. Fit Mascot and secure to bonnet, using special cup washer, part number 1744 at front fixing, nuts UCN.119/2 and shake-proof washers C.723/A
12. Fit modified front and rear chrome beads.

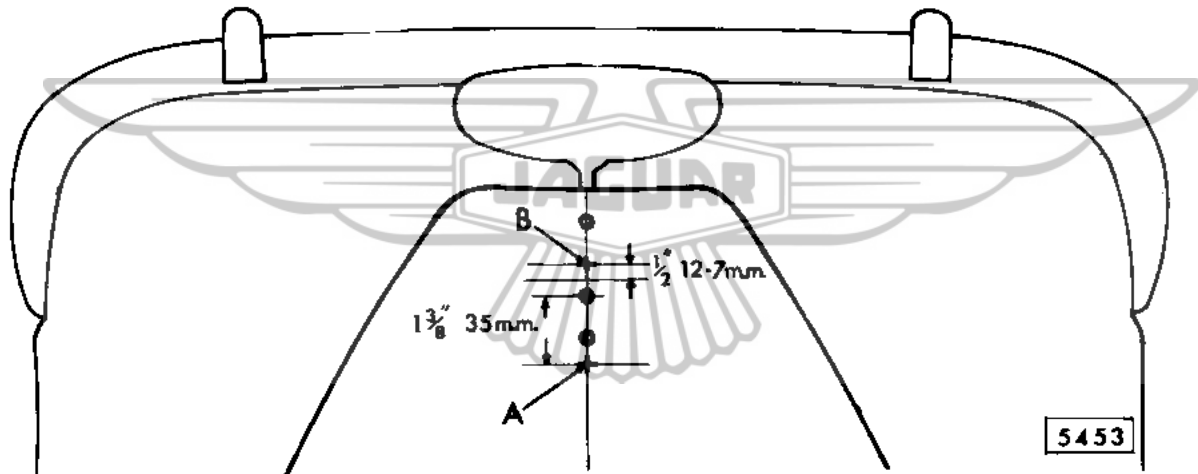

Number	N.4
Section	Body and Exhaust System
Sheet	1 (of 1)
Date	May, 1960

PAINT COLOURS

(All Models)

The following list gives the synthetic enamel colours being used in production at the present time. The reference number provided for each paint colour is for Quick Air Drying Enamel used for local repairs to the paintwork.

The date against the British Domolac colours indicates the time at which the suffix "CB" type paint was introduced on production. Cars produced after this date in the colours indicated should be repaired with "CB" type air drying enamel.

Colour	British Domolac	Finchin Johnson	I.C.I.
Black	Q1073 CB (14.1.60)		
British Racing Green	Q1076 CB (20.1.60)		
Pearl Grey	Q1129/2 CB (1.1.60)		
Carmine Red	Q1190 CB		
Sherwood Green	Q1231 CB (14.1.60)		
Indigo Blue	Q1233 CB (20.1.60)		
Cotswold Blue	Q1234 CB (20.1.60)		
Cornish Grey	Q1236 CB (14.1.60)		
Old English White			
Mist Grey			
Imperial Maroon			
Claret			

J.863 C.

J.809 C.

~~J.804~~ (M070-3311)

~~J.805~~ (M070-5176)

POB.
POB.

Number N.6
Section Body & Exhaust System

Sheet 1 (of 1)
Date February, 1961

OPALESCENT PAINT COLOURS

The following are the reference numbers for the I.C.I. Belco 300 P.031 line Quick Air Drying Enamel in the new opalescent (metallic) paint colours which were recently introduced in production.

<u>Colour</u>	<u>Q.A.D. Reference Number</u>
Blue	J.1050
Dark Green	J.1051
Gunmetal	J.1052
Silver Grey	J.1053
Silver Blue	J.1054
Bronze	J.1055



Number N.7
Section Body

Sheet 1 (of 1)

Date June, 1961

RUBBER DOOR BUFFERS

<u>Models affected</u>	<u>Commencing Chassis Numbers</u>	
	R.H. Drive	L.H. Drive
2.4 litre Mark 2	105620	126080
3.4 litre Mark 2	153583	176602
3.8 litre Mark 2	202910	215650

On cars with the above chassis numbers and onwards, a rubber buffer (Part number BD.4951) is fitted to the outer rear corner of the front and rear door sills to eliminate movement of the doors when shut.

Interchangeability is not affected by the introduction of the buffer which may also be fitted to cars prior to the above chassis numbers if desired. To incorporate this modification on such cars, it is necessary to drill a 17/64" (6.74 mm) hole in the door sills as shown in the illustration overleaf. It may be necessary to reduce the height of the buffer to ensure a perfect fit.

Spares Bulletin number P.32 refers.

WINDSCREEN GLASS

<u>Models affected</u>	<u>Commencing Chassis Numbers</u>	
	R.H. Drive	L.H. Drive
2.4 litre Mark 2	108169	126415
3.4 litre Mark 2	155308	177254
3.8 litre Mark 2	204634	217419

On cars with the above chassis numbers and onwards, toughened glass windcreens have a special built-in "zone". This special "zone" is to ensure vision in the event of the windscreen being shattered.

The new windscreen glass is interchangeable with the previous glass but it should be noted that due to the introduction of the "zoned" area the new glass is "handed" according to whether the car is L.H. Drive or R.H. Drive.

Spares Bulletin number P.35 refers.

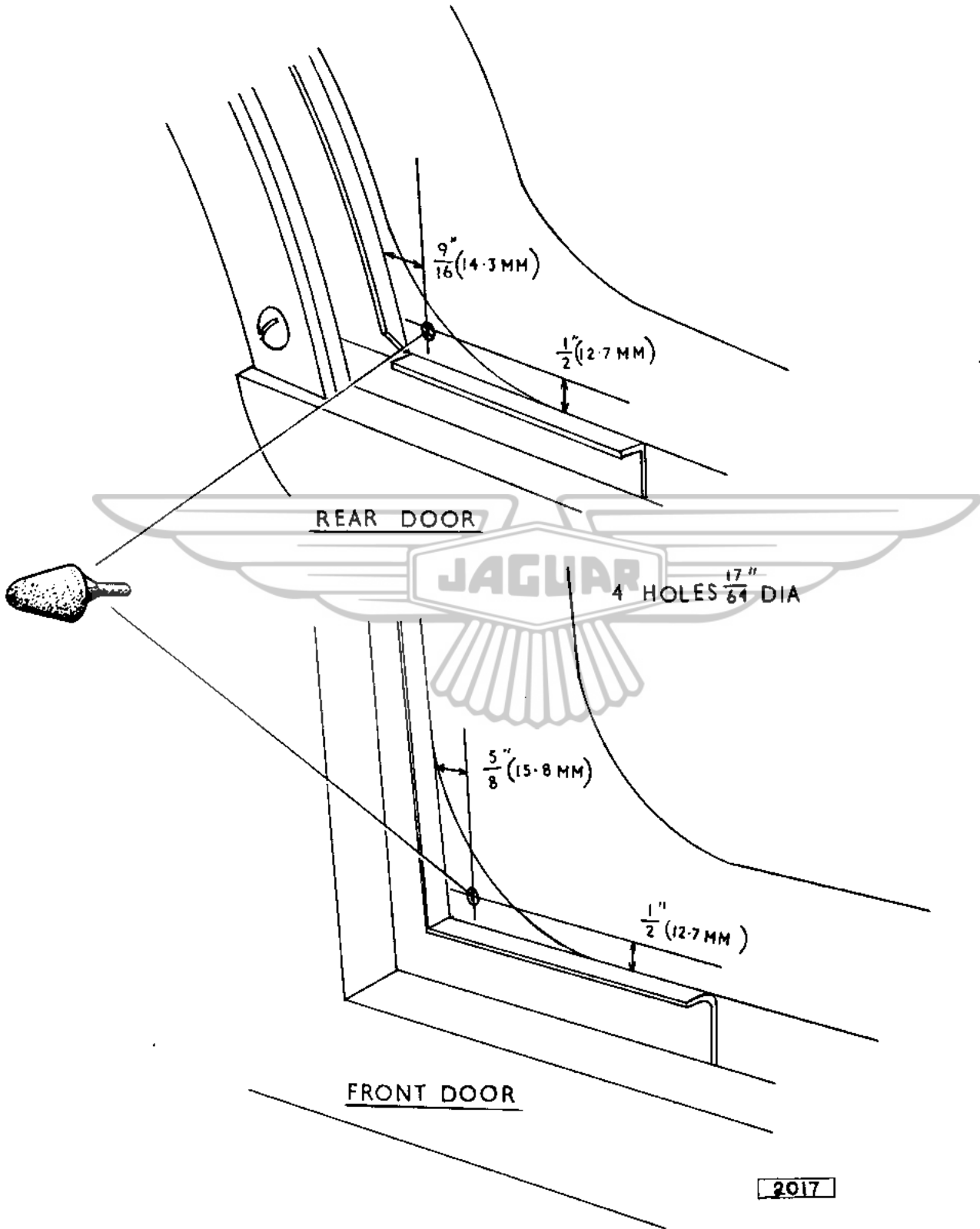

2017

Number N.8.
Section Body

Sheet 1 (of 1)
Date October, 1961.

BONNET LOCK - MODIFIED TYPE

Models affected

Commencing Chassis Numbers

	R.H. Drive	L.H. Drive
"E" Type Fixed Head Coupe	860005	885021
Open 2-seater	850092	875386

On cars with the above chassis numbers and onwards, a revised bonnet locking system is incorporated. The bonnet is fastened and released by means of two small levers one on either door hinge pillar.

To open the bonnet, turn the levers anti-clockwise and pull out to their full extent. Insert the fingers under the rear edge of the bonnet, press in the safety catch and raise the bonnet. To close the bonnet, push the bonnet closed, then applying pressure to the top of the bonnet, push the lever fully home and turn clockwise. Repeat for the other side of the bonnet. It is MOST IMPORTANT to ensure that the levers are out to their full extent and have not been pushed in accidentally before attempting to close the bonnet or the bonnet may be damaged.

WIND NOISE

Mark 2 Models

In cases of complaint of wind noise from the front edges of the front doors on Mark 2 models, it is recommended that a rubber sealing strip is fitted to the forward edge of the doors adjacent to the top hinge.

To fit the strip (Part Number BD.21361 (L.H.), BD.21362 (R.H.)) remove the front door capping and waist rail and pull the top of the door trim casing away from below the window aperture. Slacken the two screws below the no draught ventilator and pull the frame away from the door. Using a suitable adhesive, stick the sealing strip to the forward edge of the door so that the upper end is trapped by the no draught ventilator frame (see illustration overleaf). Tighten the securing screws, restick the door casing trim and refit the waist rail and door capping.

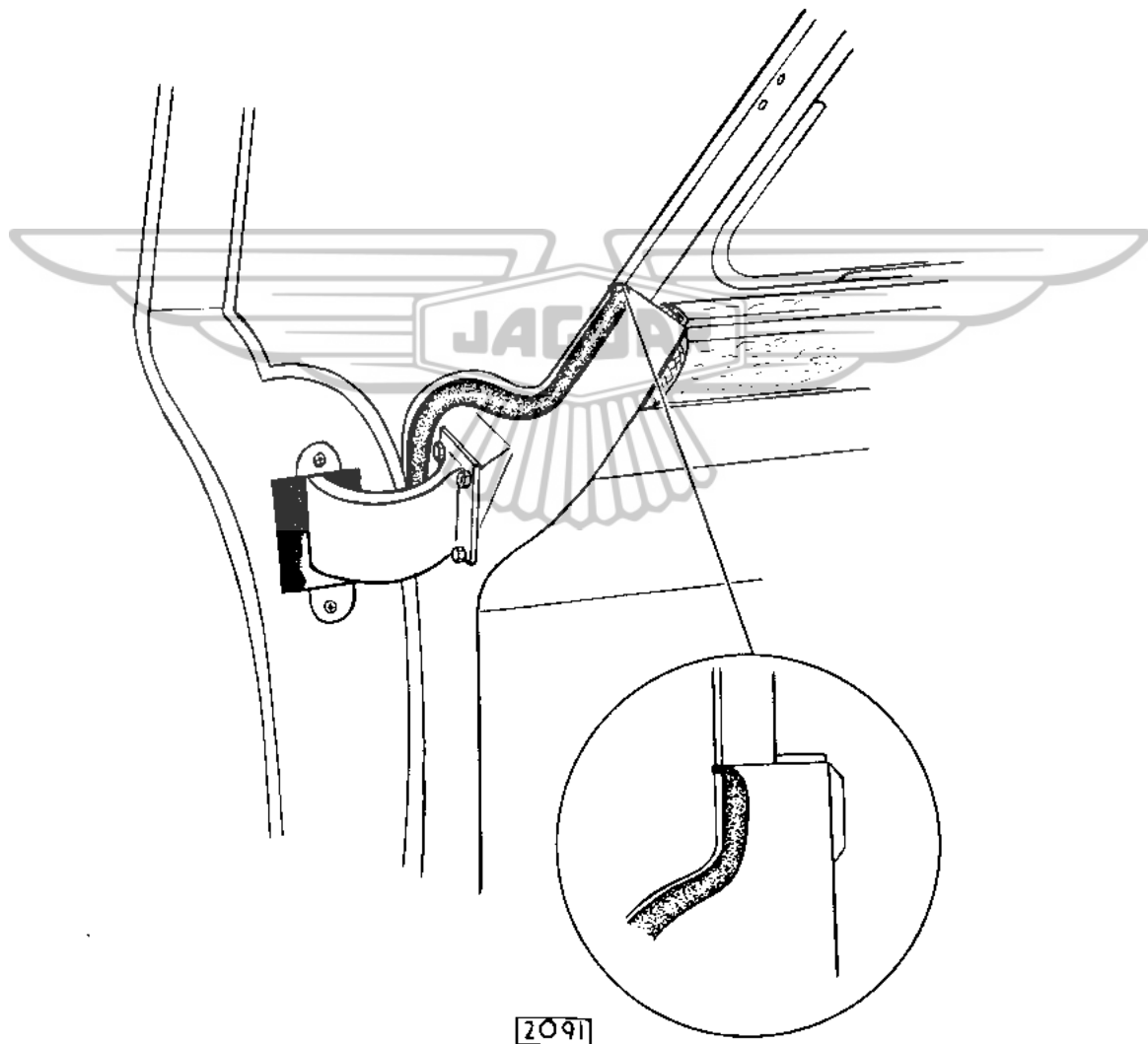

Number N.9.
Section Body and Exhaust
System
Sheet 1 (of 1)
Date December, 1961

EXCESSIVE HEAT IN THE DRIVING COMPARTMENT

(Mark 2 Automatic Transmission)

If trouble is experienced with excessive heat in the driving compartment of Mark 2 cars fitted with automatic transmission (prior to the fitting of the remote dipstick - Service Bulletin number FF.3) the following checks should be made:-

1. That the rubber plug blanking the dipstick hole in the gearbox cover is in position.
2. That the felt blank is in position on top of the rubber plug.

It should be brought to the attention of lubrication bay operators that both these parts must be refitted correctly after checking the oil level of the automatic transmission.

DOOR LOCK MODIFICATION

(Mark 2 Models)

If trouble is experienced with the door locks jamming when the outside button and inside lever are operated at the same time, the following modification should be carried out.

Remove the door casing, wood capping and plastic covering as described in Section N "Body and Exhaust System" of the Mark 2 Service Manual. Move the inner door handle into the locked position. This action moves the plunger operating lever from behind the lock contactor. Slacken the lock nut and unscrew the push button plunger bolt (shown in the illustration overleaf). Discard the hexagon headed bolt and screw the locknut onto the countersunk cross-headed screw (Part Number 8949). Screw the countersunk screw into the plunger operating lever. The clearance between the head of the plunger screw and the lock contactor should be 1/32" (0.8 mm). To adjust, slacken the locknut, screw the plunger screw in or out as required and retighten the locknut.

Refitting the plastic covering, door casing and wood capping is the reverse of the removal procedure.

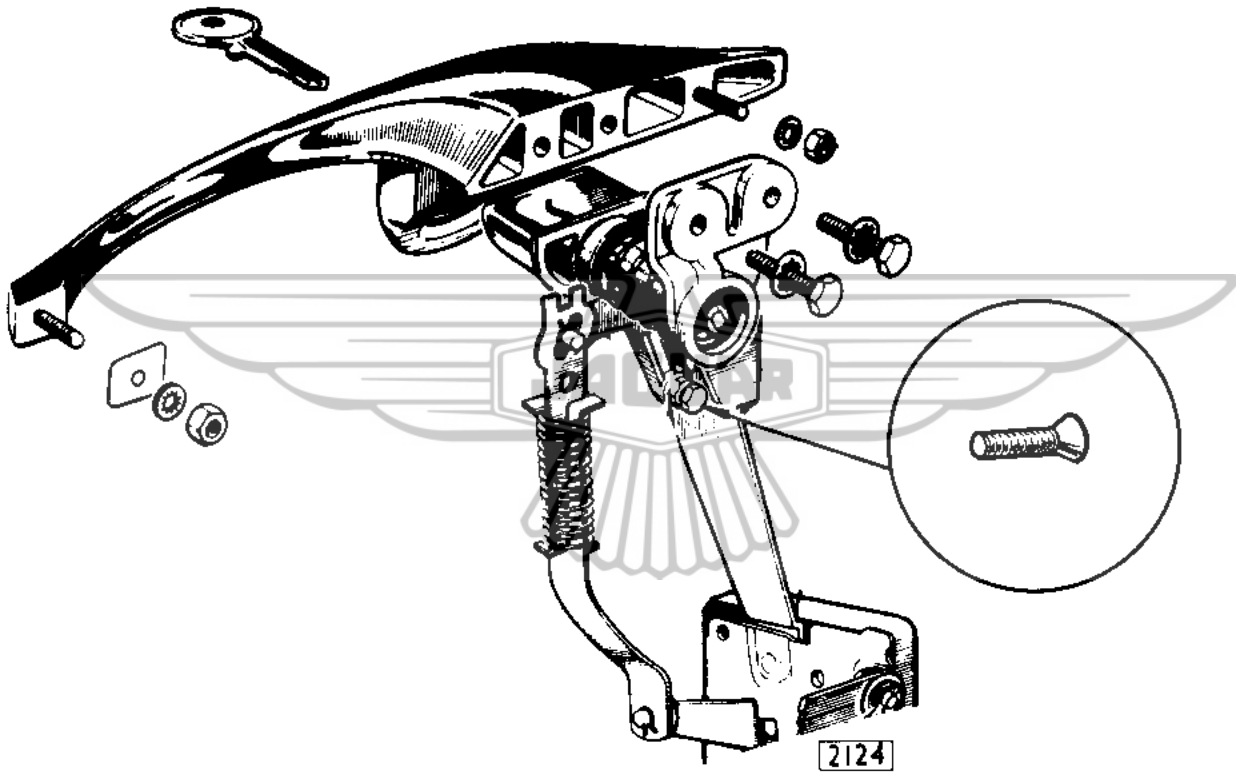

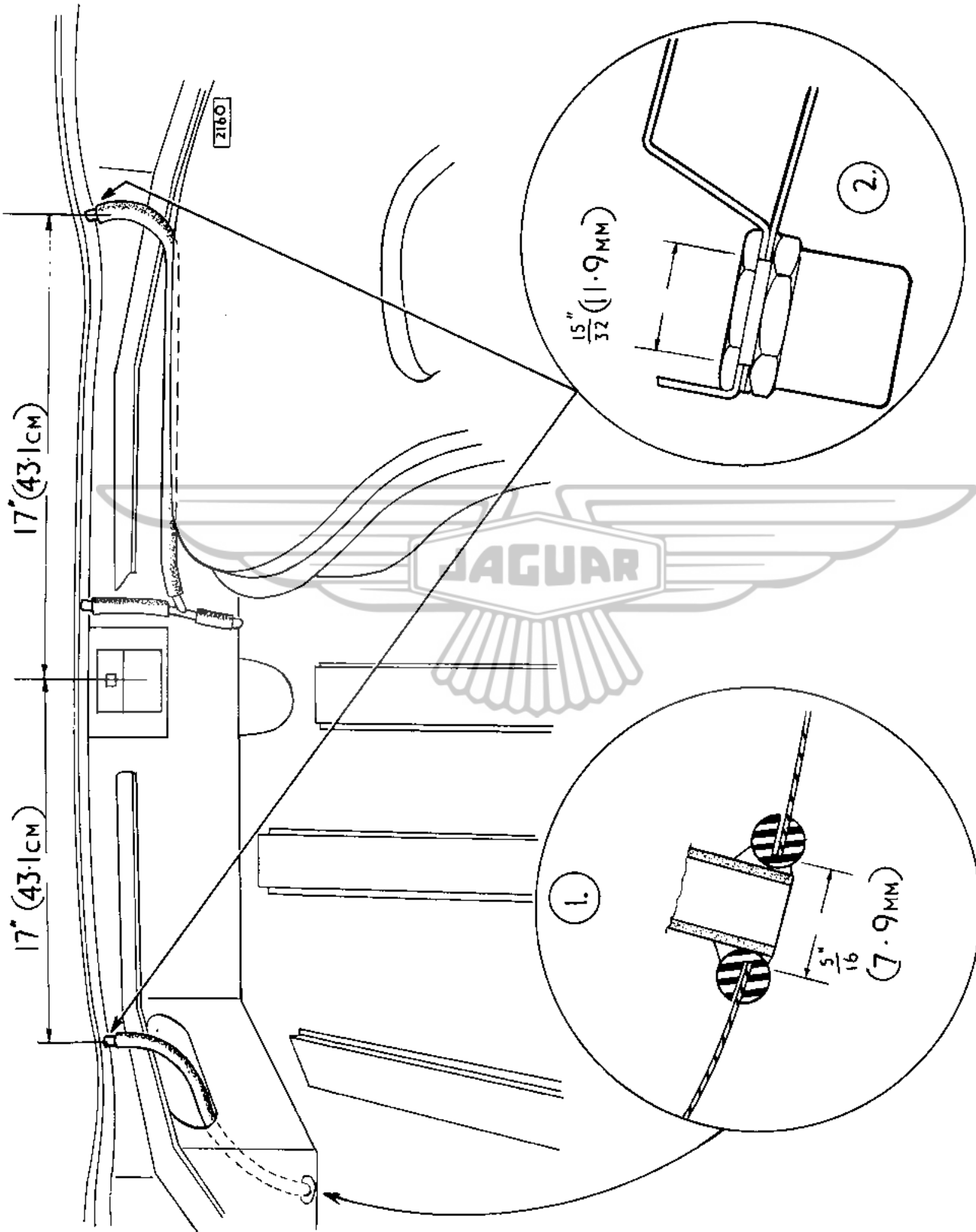

Number N.11
 Section Body & Exhaust
 System
 Sheet 1 (of 1)
 Date January, 1962

ACCIDENTAL DAMAGE TO THE FRONT FRAME

("E" Type)

It is most important when accidental damage has been sustained to the Front Frame that the appropriate sub-frame assembly should be replaced. NO ATTEMPT SHOULD BE MADE TO WELD OR BRAZE REPLACEMENT TUBES INTO THESE ASSEMBLIES NOR SHOULD HEAT IN ANY FORM BE APPLIED IN AN EFFORT TO STRAIGHTEN THEM.

The breakdown of the Front Frame assembly is given on pages 157 to 159 of the "E" Type Spare Parts Catalogue.

SEAT BELT ATTACHMENT POINTS

Models affected

Commencing Chassis Numbers

2.4 litre Mark 2
 3.4 litre Mark 2
 3.8 litre Mark 2
 "E" Type Open 2-seater
 "E" Type Fixed Head Coupe
 Mark 10

R.H. Drive L.H. Drive

111418	126652
158371	177753
207313	219801
850301	876359
860113	885318

From commencement of production.

See Bulletin N14

On cars with the above chassis numbers and onwards, mounting points for the attachment of seat belt anchor brackets are provided. The mounting points are in the positions shown overleaf and are designed to suit a wide range of seat belt types. The pairs of holes for floor mountings are $2\frac{1}{2}$ " (6.35 cm) between centres, one hole being a $\frac{3}{8}$ " (9.5 mm) plain clearance hole and the other being a $7/16$ " (11.1 mm) UNF tapped hole. The mountings holes behind the seats or on the centre pillars are all tapped $7/16$ " (11.1 mm) UNF. (See illustrations overleaf).

On cars supplied to North America, eye bolts are fitted to the tapped holes on the floor mountings behind the front and rear seats.

/Continued overleaf...

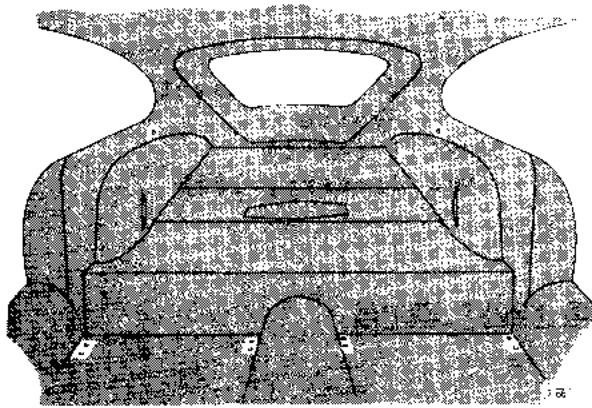

'E' TYPE FIXED HEAD COUPE

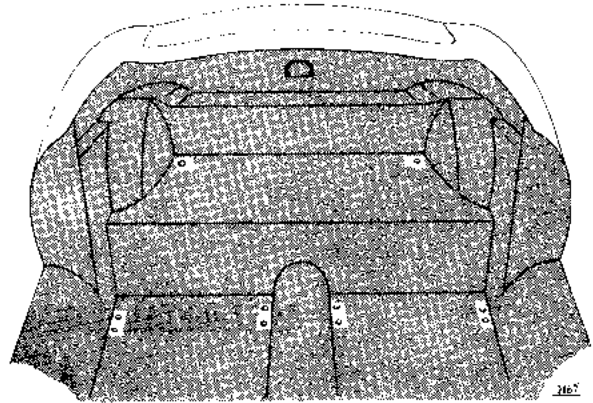

'E' TYPE OPEN 2 SEATER

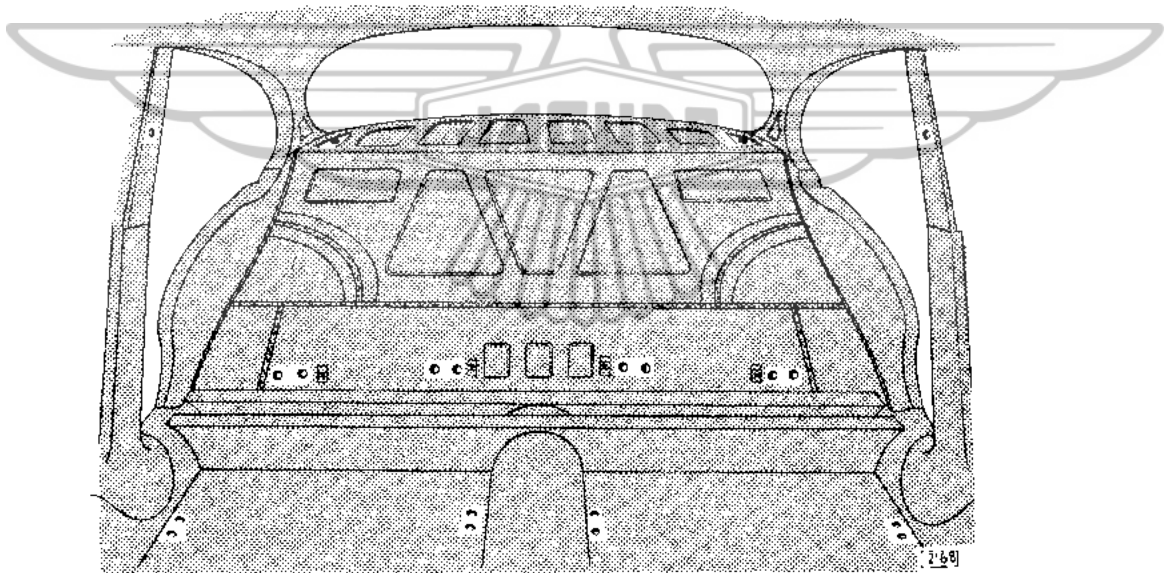

MARK 2 AND MARK 10 MODELS

Amendment to Service Bulletin Number N.10.

Owing to a typographical error, the diameter of the hole drilled in the luggage compartment floor was incorrectly stated as 5/16" (7.9 mm). This dimension should be altered both in the text and on the illustration to read 15/16"(23.8 mm).

Number N.13.
Section Body & Exhaust
System
Sheet 1 (of 1)
Date March, 1962

ADJUSTMENT OF BONNET COMPENSATOR MECHANISM
("E" Type)

If there is evidence of the bonnet compensator mechanism fouling the rack and pinion steering bellows, the compensator linkage should be adjusted as follows.

Slacken the four setscrews securing the front of the appropriate compensator linkage to the bonnet. Adjust the securing bracket to a position where (with the bonnet closed) there is adequate clearance between the bonnet springs and the bellows and also between the top of the linkage and the bonnet side member. Tighten the four setscrews and ensure that the bonnet closes correctly before securing.



OPALESCENT PAINT REFINISHING

(All Models)

Enclosed with this bulletin is a leaflet giving information on the refinishing of paintwork on cars originally finished in opalescent colours.

Supplies and further information may be obtained by Distributors and Dealers in the British Isles from the various branches of Brown Brothers Limited or Thompson and Brown Brothers Limited. Overseas Distributors and Dealers should contact their nearest I.C.I. agent.

Number N.14. (2nd issue)
Section Body

Sheet 1 (of 1)
Date March, 1963.

JAGUAR SEAT BELTS.

This bulletin supersedes the original issue of April 1962 which should be destroyed.

<u>Models affected</u>	<u>Commencing Chassis Numbers</u>	
	R.H. Drive	L.H. Drive
2.4 litre Mark 2	111418	126652
3.4 litre Mark 2	158371	177753
3.8 litre Mark 2	207313	219801
'E' Type Open 2-seater	850301	876359
Fixed Head Coupe	860113	885318
Mark 10	From commencement of production.	

For cars with built-in seat belt anchorages, (that is, on and after the above chassis numbers) official Jaguar seat belts will soon be available. These belts will be marketed solely by this company and will be supplied only through the Jaguar Spares Division.

The part numbers of the seat belt kits for all models are as follows and will include the necessary attachment bolts and eyebolts.

	Part No.
Front seat belt (lap/diagonal)	9212
Rear seat belt (diagonal)	9213

The positions of the anchorage points are shown overleaf. Earlier cars had two holes, one plain and one tapped, at the floor anchorage positions; later cars have only a single 7/16" (11.1 mm) U.N.F. tapped hole. In either case only the tapped holes will be used for anchorage purposes.

Note: The tapped holes in the floor are blanked off with plastic cross headed screws. On the Mark 2 and Mark 10 models, the tapped hole in each centre pillar is blanked off with a chrome plated escutcheon.

Full fitting instructions will be included with each belt.

LATER CARS

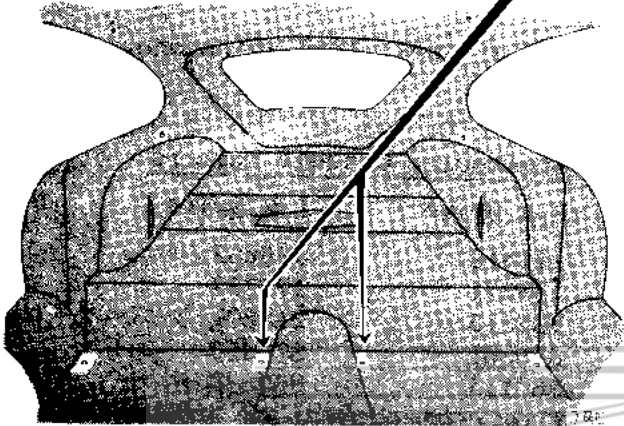
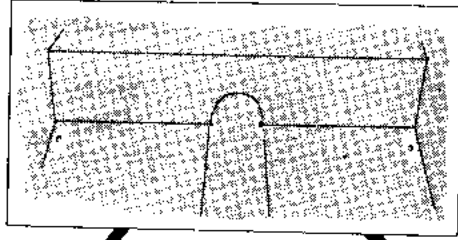

'E' TYPE FIXED HEAD COUPE
EARLY CARS

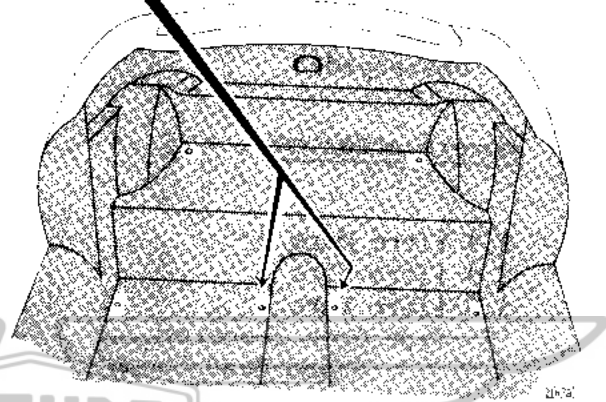

'E' TYPE OPEN 2 SEATER
EARLY CARS

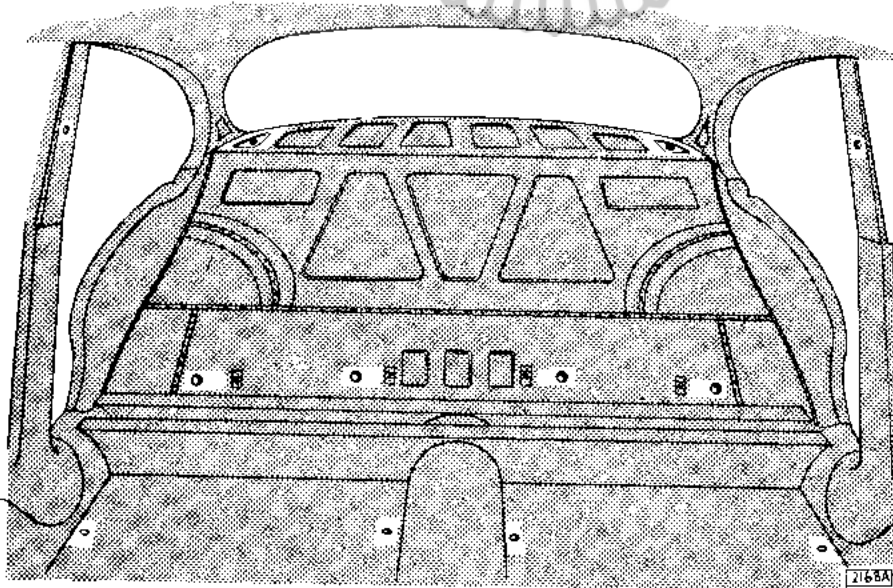

MARK 2 AND MARK 10 MODELS

Number N.19
Section Body and Exhaust System
Sheet 1 (of 1)
Date October, 1962

ADDITIONAL PAINT COLOUR

Quoted below is the reference number for the new I.C.I. paint colour recently introduced in production.

<u>Colour</u>	<u>Q.A.D. Reference Number</u>
Golden Sand	J.1066

<u>MODIFIED BODY REAR FRAME BRACKETS</u>		
<u>Model affected</u>	<u>Commencing Chassis Numbers</u>	
	<u>R.H. Drive</u>	<u>L. H. DRIVE</u>
Mark 10	300981	351388
Also introduced on 3)	300718	351135
individual cars.)	-	351263

Commencing at the above chassis numbers the rear suspension mounting holes in the rear frame brackets (which are integral with the body) are re-positioned to suit the new rear suspension crossbeam (See Service Bulletin K.6). It is only possible to fit the new crossbeam (Part No. C.20174) to the bodies with the latest rear frame brackets.

Spares Bulletin No: P. 69 refers.

Number N.22.

Section Body and Exhaust System

Sheet 1 (of 1)

Date March, 1963.

INSTRUCTIONS FOR FITTING RECLINING MECHANISM.

TO SPECIAL ADAPTABLE TYPE FRONT SEATS.

<u>Model affected</u>	<u>Commencing Chassis Numbers</u>	
	<u>R.H.Drive</u>	<u>L.H.Drive</u>
2.4 litre Mark 2.	115017	127082
3.4 litre Mark 2.	162688	179029
3.8 litre Mark 2.	230325	222338

Commencing at the above chassis numbers, the front seats of Mark 2 cars can be converted to the reclining type.

The part numbers of conversion kits are:-

BD.24397 For Left - hand seat

BD.24432 For Right - hand seat

Remove the front seat as detailed in the Mark 2 Service Manual, Section M "Body" page M.21 and turn the seat over with the base uppermost.

Remove the tie rods (2 per seat) locking the seat base to the squab, after extracting the setscrews, nuts, and washers. (see illustration overleaf)

Check that the rack protrudes from each slide tube assembly by an equal amount. Adjust if necessary by turning one of the operating lever rods and releasing the rack pawl.

Attach the inner (short) slide tube assembly to the seat base front pivot with a clevis pin and three brass washers, locating two washers between the lugs on the tube assembly and the seat base and the remaining washer under the split pin.

Repeat the operation to the outer (long) slide tube assembly ensuring that the two halves of the operating rod centre coupling are mated correctly.

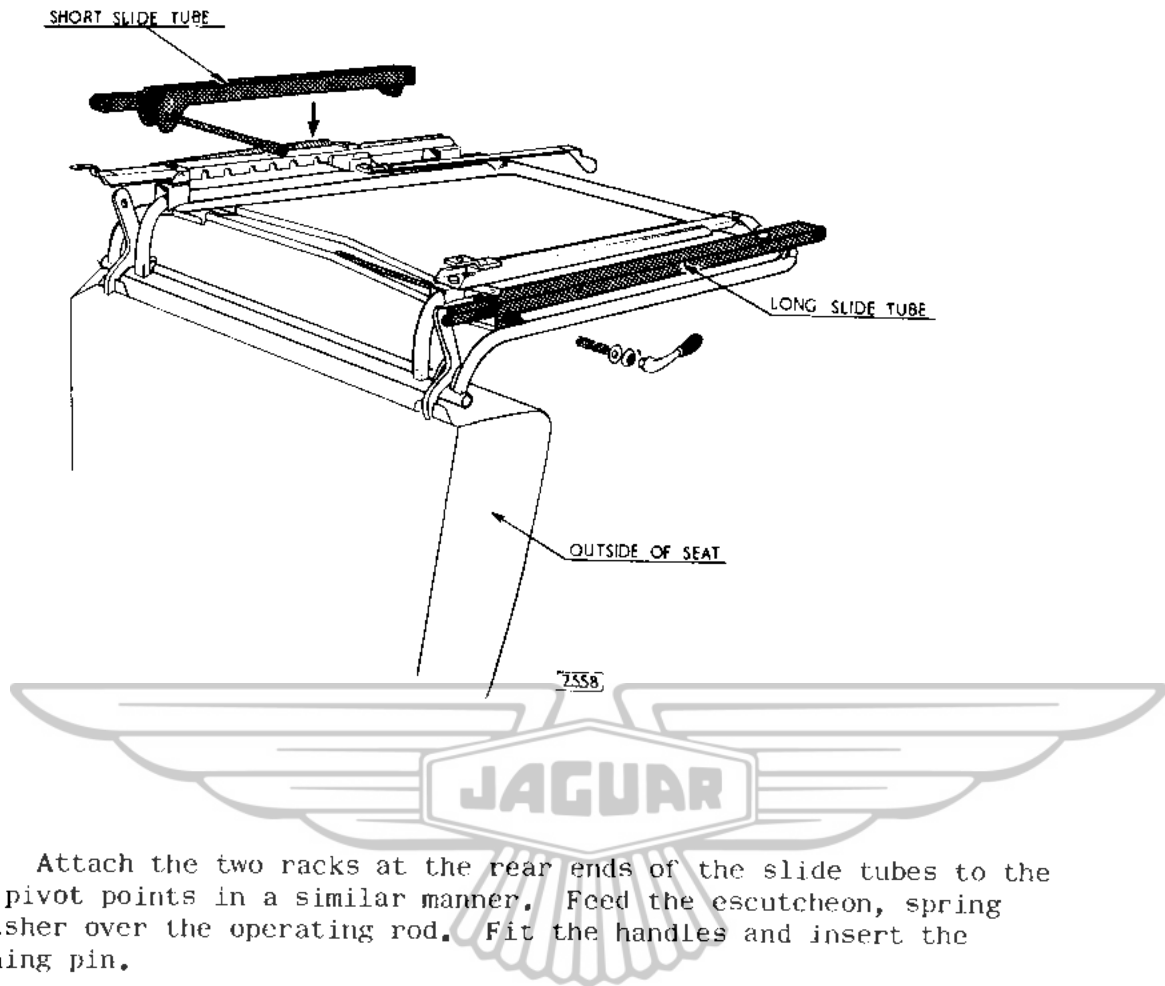

Attach the two racks at the rear ends of the slide tubes to the squab pivot points in a similar manner. Feed the escutcheon, spring and washer over the operating rod. Fit the handles and insert the retaining pin.

NOTE: The handles are handed and must be fitted with the lever knob towards the front and curving downwards.
Lubricate all pivot points with oil and coat the racks lightly with grease.

Refit the seat to the car,

Locate the recessed section of the cushion spring casing lower edge. Slit the seat trimming locally in the section, turn back and secure with upholstery solution.

Lower the seat squab and fit the cushion noting that the escutcheon is positioned outside the seat trimming.

Lift the release lever and raise the squab to the desired position.

Spares Bulletin No. P.76. refers.

Number N.22. (2nd issue)
Section Body and Exhaust System.

Sheet 1 (of 2)
Date May, 1964.

This Service Bulletin supersedes the original issue of March, 1963 which should be destroyed.

INSTRUCTIONS FOR FITTING RECLINING MECHANISM
TO SPECIAL ADAPTABLE TYPE FRONT SEATS.

<u>Models affected.</u>	<u>Commencing chassis numbers.</u>	
	<u>R.H.Drive.</u>	<u>L.H.Drive.</u>
2.4 litre Mark 2	115017	127082
3.4 litre Mark 2	162688	179029
3.8 litre Mark 2	230325	222338

Commencing at the above chassis numbers, the front seats of Mark 2 cars can be converted to the reclining type.

The part numbers of conversion kits are:-

BD.24397 For Left-hand seat.

BD.24432 For Right-hand seat.

Remove the front seat as detailed in the Mark 2 Service Manual, Section M "Body" page M.21 and turn the seat over with the base uppermost.

Remove the tie rods (2 per seat) locking the seat base to the squab, after extracting the setscrews, nuts and washers (see illustration).

Check that the operating rods will pass through the pivot holes in slide tube brackets.

Attach the lock spring to the locking lever. Fit the spring with the square loop over the top of the lever and the circular loop passing under the lever pivot bosses.

Feed the lever between the slide tube brackets and hook the spring into the two small holes.

Line up the lever with the holes in the bracket and insert the operating rod as shown in the illustration.

Secure the lever to the operating rod with an Allen headed grub screw ensuring that the screw registers with the ident in the rod.

Raise the lever and trap in the raised position with a screwdriver.

Insert the correct spring and follow with the rack. Force the rack against the spring into the slide tube until only five slots are visible. Remove the screwdriver and lock the rack in this position.

WARNING: DUE TO THE RACK BEING UNDER CONSIDERABLE SPRING PRESSURE, DO NOT RAISE THE LOCKING LEVER BY TURNING THE ROD UNTIL THE ASSEMBLY OF THE SEAT IS COMPLETED.

Check that the rack protrudes from each slide tube assembly by an equal amount. Adjust if necessary by turning one of the operating lever rods and releasing the rack pawl.

Attach the inner (short) slide tube assembly to the seat base front pivot with a clevis pin and three brass washers, locating two washers between the lugs on the tube assembly and the seat base and the remaining washer under the split pin.

Repeat the operation to the outer (long) slide tube assembly ensuring that the two halves of the operating rod centre coupling are mated correctly.

Attach the two racks at the rear ends of the slide tubes to the squab pivot points in a similar manner.

Feed the spring, washer and escutcheon over the operating rod. Fit the handle, with the lever pointing to the front, press the rubber washer, provided in the kit, into the square bore of the handle before fitting and insert the retaining pin.

Fit the knob to the lever, the knob must curve downwards when fitted and secure with the raised-headed drive screw.

Refit the seat to the car.

Locate the recessed section of the cushion spring casing lower edge. Slit the seat trimming locally in the section, turn back and secure with upholstery solution.

Lower the seat squab and fit the cushion noting that the escutcheon is positioned outside the seat trimming.

Lift the release lever and raise the squab to the desired position.

Spares Bulletin No. P.76 Refers.

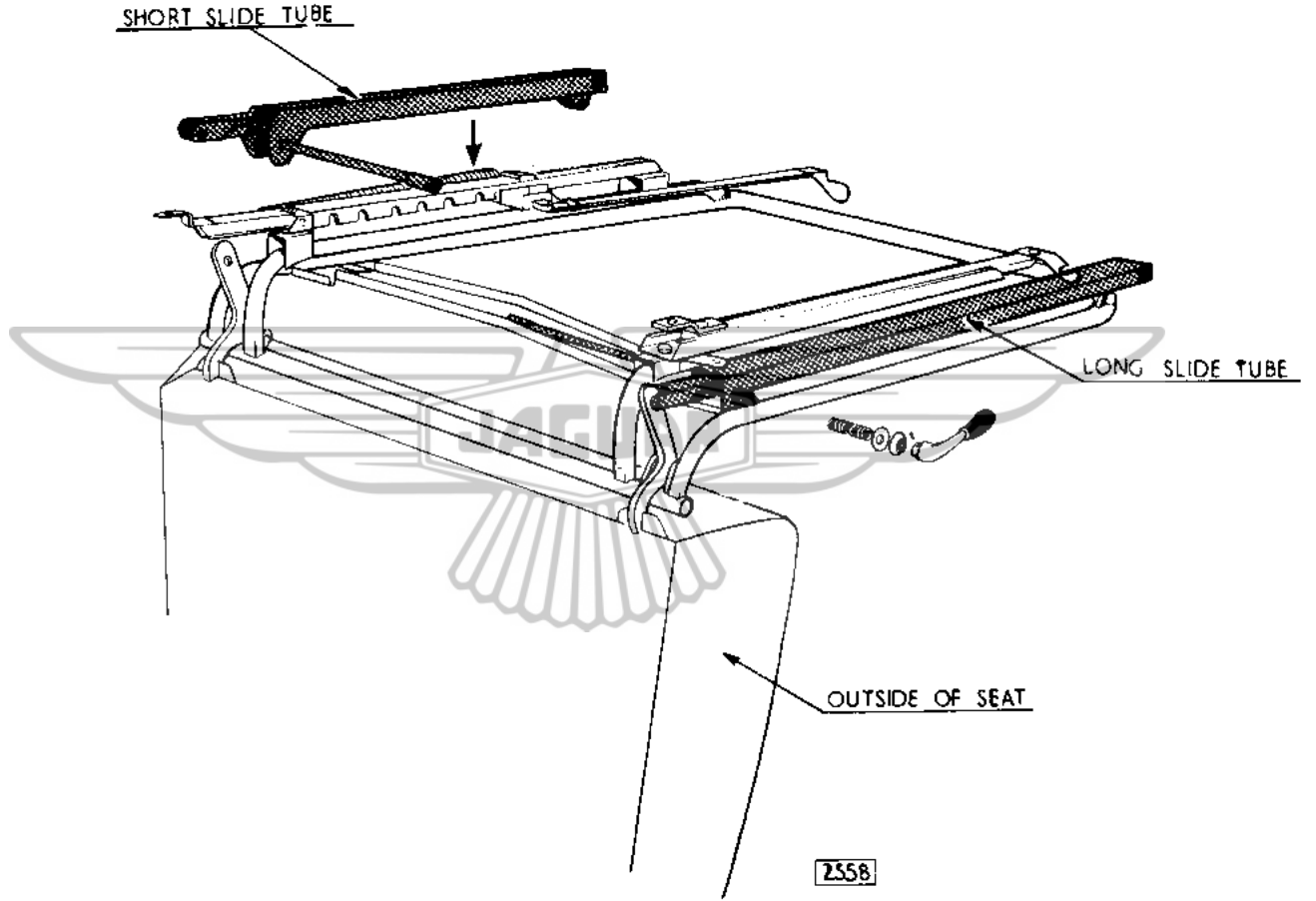

Number N.23.
Section Body and Exhaust System.

Sheet 1 (of 1)

Date April, 1963.

MODIFIED DOOR LIGHT FRAMES.

Models affected.

Mark 2 2.4 litre
Mark 2 3.4 litre
Mark 2 3.8 litre

Commencing Chassis Numbers.

<u>R.H.Drive.</u>	<u>L.H.Drive.</u>
114992	127075
162651	179010
230298	222289

Commencing at the above chassis numbers, a modified door light frame incorporating flocked rubber channel inserts and a new window glass are introduced on Mark 2 Models.

The door light frames are interchangeable with the existing units provided the relevant window channel inserts and glass are also incorporated.

Spares Bulletin No. P.80 refers.

Number N.25.
Section Body and Exhaust System.

Sheet 1 (of 1)

Date October, 1963.

MODIFIED EXHAUST SYSTEM.

Models affected

Commencing chassis numbers.

'E' Type Open 2 seater
Fixed Head Coupe.

R.H.Drive

850755

861271

L.H.Drive.

879990

889096

Commencing with the above chassis numbers a modified exhaust system which gives improved silencing is fitted.

The new mufflers are less effective in sound absorption than their predecessors and must not be used with the previous type of silencers.

For full details of interchangeability see Spares Bulletin M.23.

CHURCHILL '700' BODY CHECKING AND REPAIR JIG.

(Mark 1 2.4/3.4 litre, Mark 2, 'E' Type and Mark 10 Models).

The Churchill '700' system for the checking and repair of bodies has now been extended to cover the above Jaguar models. Additional adaptors are also being developed to suit the 3.4/3.8 'S' models.

Distributors and Dealers who require this equipment should approach Messrs. V.L.Churchill & Co. Limited of Great South West Road, Bedford, Feltham, Middlesex direct.

The main feature of this equipment is its adaptability for present and future models. The basic equipment consists of transverse members affixed to two 'I' section beams in pre-determined positions. Adaptors to suit various models are bolted to the transverse members and "pick-up" the important points in the body underframe.

It is desirable that this equipment is purchased complete, but in special circumstances Churchills are prepared to provide drawings to enable locally purchased beams to be drilled.

In view of the close limits to which these beams have to be drilled, this procedure should be adopted only in cases where it is impossible to import the finished product.

Mark 10 Front End Jig (J.710).

A further jig for the Mark 10 model is also available.

This jig picks up at the front engine mounting points, the engine stabiliser bracket on the bulkhead and at the bonnet hinge points on the front crossmember. It can be used in conjunction with the main jig or separately for the treatment of localised front end damage.



Number N.31.
Section Body.

Sheet 1 (of 1)

Date October, 1964.

SUPPLY OF FRONT WINGS.

(Mark 2 and 3.4/3.8 'S' models)

When stocks of the present front wings are exhausted, future supplies will be less the baffle plate which will be issued as a separate item. The new condition of front wings will have the suffix 'A' to the existing part number to distinguish them from the previous condition.

	<u>Part number.</u>
<u>Mark 2 Models</u>	
Front wing - right hand	8007A
Front wing - left hand	8008A
 <u>3.4/3.8 'S'</u>	
Front wing - right hand	10139A
Front wing - left hand	10140A
 <u>Mark 2 and 3.4/3.8 'S' Models</u>	
Baffle plate - right hand	10529
Baffle plate - left hand	10530

Spares bulletin No. P.135 refers.

Number N.32.
Section Body.

Sheet 1 (of 1)
Date December, 1964.

ADDITIONAL PAINT COLOURS.

The following are the reference numbers of Quick Air Drying Enamel for the new paint colours recently introduced in production.

<u>Colour.</u>	<u>Q.A.D. Reference Number.</u>	<u>Manufacturer.</u>
Warwick Grey	J.932	Pinchin-Johnson
Dark Blue (Not Opalescent)	J.1080	I.C.I.
Pale Primrose.	J.1076	I.C.I.



Number N.33
Section Body

Sheet 1 (of 1)
Date November, 1965

REAR NO DRAUGHT VENTILATOR CATCH

<u>Models affected</u>	<u>Commencing chassis numbers</u>	
	<u>R.H.D.</u>	<u>L.H.D.</u>
2.4 litre Mark 2	119204	127824
3.4 litre Mark 2	169388	180201
3.8 litre Mark 2	234215	224161
3.4 'S' Type	1B4607	1B26515
3.8 'S' Type	1B55057	1B78169
4.2 Mark 10	1D51220	1D75742

Commencing at the above chassis numbers the threads of the Rear No Draught Ventilator pivot screws are coated with "LOCTITE" Sealant to prevent the screws working loose.

If complaints are received of these screws working loose on cars previous to the above chassis numbers the threads should be treated as follows:

Close the ventilator and remove the locknut and pivot screw securing the lever to the ventilator frame (note fibre washer). Remove the two screws and detach the catch from the door.

Remove the hexagon headed pivot screw, spring and plain washer from the underside of the catch.

Wash in cleansing solvent to remove all oil or grease.

Coat the thread with "LOCTITE" and reassemble.

Refit the catch and connect to the ventilator frame.

Allow time (12 hrs. approx.) for the sealant to harden before operating the catch.

Number N.35
Section Body

Sheet 1 (of 1)
Date April, 1966

DOOR WINDOW GLASS AND SEALS

Model affected

4.2 'E' type

Commencing chassis numbers

<u>R.H. Drive</u>	<u>L.H. Drive</u>
1E.20953	1E.31920

Commencing at the above chassis numbers 4.2 'E' type Fixed Head coupe models are fitted with window frame seals of flocked rubber material, replacing the felt seals previously fitted.

The parts introduced by this modification are replaceable only in sets.

The removal and refitting procedure for the glass remains the same as that stated in the 'E' type Service Manual - Section N.

When fitting new seals retain in position by coating the inside of the channel with Bostik Cement. Allow the cement to get tacky before inserting the seals. Trim off with a sharp knife after fitting.

Spares Bulletin P.158 refers.

Number N.36
Section Body and Exhaust

Sheet 1 (of 1)
Date April, 1966

PAINT COLOURS
(All Models)

The following list gives the paint colour range being used in current production.

The reference numbers quoted against each paint colour is for Quick-Air drying enamel used for local repairs to the paintwork following accident damage.

REPAIR ENAMEL

	SUPPLIER	REF. NO.	THINNERS NO.	
OPALESCENT SILVER BLUE	I.C.I.	PO31-2640	851/222)	
" SILVER GREY	I.C.I.	PO31-2639	851/222)	I.C.I.
PRIMROSE	I.C.I.	PO30-3297	851/222)	
SHERWOOD GREEN	BERGER	4D.1824	851/222)	
CARMEN RED	BERGER	4D.1897	851/222)	BERGER
OPALESCENT MAROON	P.J.	CLR.7	851/222)	
OLD ENGLISH WHITE	P.J.	C/768x0110	851/222)	P.J.
WARWICK GREY	P.J.	765F2615	851/222)	
BLACK	G.I.P.	CL.5030	851/222)	
DARK BLUE	G.T.P.	LC.25250	851/222)	
OPALESCENT DARK GREEN	G.T.P.	LC.24734/M	851/222)	G.I.P.
" GOLDEN SAND	G.T.P.	CL.24337/M	851/222)	
OPALESCENT (NEW LIGHT) MAROON	P.J.	CLR.23	851/222)	P.J.

Number N.57

Section Body and Exhaust

Page 1 of 3

Date December, 1966

BRITAX 'AUTOLOK' SEAT BELT
INSTRUCTIONS FOR FITTING TO CURRENT PRODUCTION
2.4/3.4/3.8 LITRE MARK 2, 3.4/3.8 'S' TYPE AND
420 CARS

The 'Autolok' reel is, in all cases, mounted on the centre pillar, right or left hand as required.

Fitting Instructions (see Illustration)

- (1) Insert a thin-bladed screwdriver behind the trim casing and the centre pillar ('B/C' Post). Prise off the casing from the clip fixing, pull downwards and remove. Knock off the polished wood capping down by hand and detach from the pillar. Press out chrome button from wood capping.
- (2) Mark off a point $\frac{1}{2}$ " (12.7 mm.) above the lower clip fixing hole on the centre pillar and drill to $\frac{15}{32}$ " (11.9 mm.) diameter centrally in the 'B/C' Post.
- (3) Offer up the bottom reinforcement plate (tapped $\frac{7}{16}$ ") and mark off the location of the small hole on the centre pillar. The hole should be on the same horizontal centre line and forward of the main hole. Drill out to $\frac{1}{4}$ " (6.4 mm.) diameter.
- (4) Insert the plate through the hinge pocket in the pillar and secure into position with the cross-headed drive screw supplied in the kit.
- (5) Increase the diameter of the third clip fixing hole to $\frac{11}{32}$ " (8.7 mm.) and using the top reinforcement plate (tapped $\frac{5}{16}$ ") as a template, mark off the location of the small hole on the pillar. The hole should be on the same vertical centre line and above the main hole.
- (6) Position the plate behind the centre pillar face and secure with the cross-headed screw.
- (7) Pierce holes in the trim casing to correspond with the location of the $\frac{11}{32}$ " (8.7 mm.) and $\frac{15}{32}$ " (11.9 mm.) holes in the 'B/C' Post.
- (8) Refit the trim casing and wooden capping.

/cont'd....

- (9) Attach the reel to the bracket with the two 5/16" setscrews, nuts and lockwashers. Note that the unit must be fitted so that the strap unreels against the back of the bracket. Attach the mounting bracket to the 'B/C' Post with the 5/16" and 7/16" setscrews, plain and lockwashers; the two distance pieces supplied in the kit should be interposed between the bracket and the trimming (Fig. 2). Tighten the setscrews fully.
- (10) Place the wavy washer on the small diameter of the mounting bush supplied in the kit and insert the bush into the hole in the strap top anchor plate from the back. Pass the large plated setscrew with plain washer through the plate and bush.
- (11) Fit the bush in the hole in the wood capping and fully tighten the setscrew into the tapped boss on the pillar.
- (12) Slide the seat forward and withdraw the two black plastic plugs from the floor between the seat runners. Insert the two eyebolts and tighten fully.
- (13) Attach the main belt to the outer eyebolt and the short (buckle) belt to the inner eyebolt. Re-adjust the seat position. (Fig. 1, reference C).

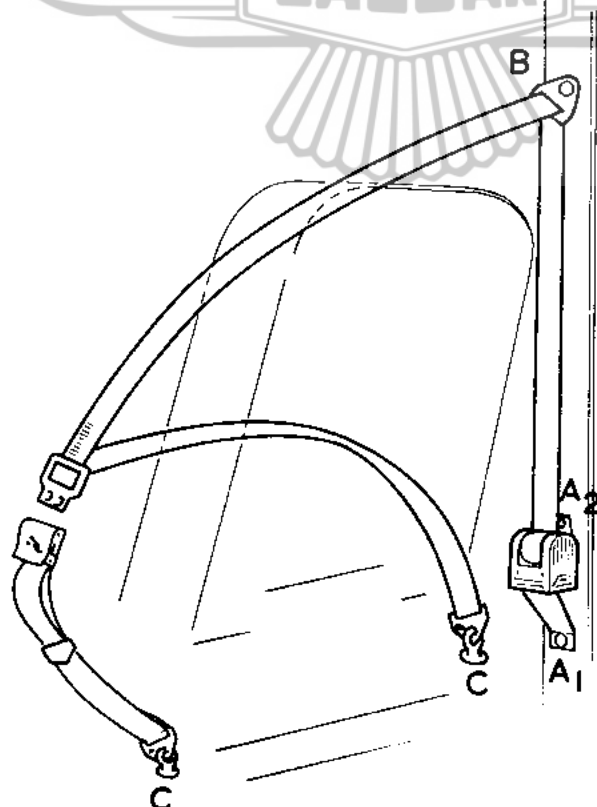

FIG. 1 THE SEAT BELT FITTED

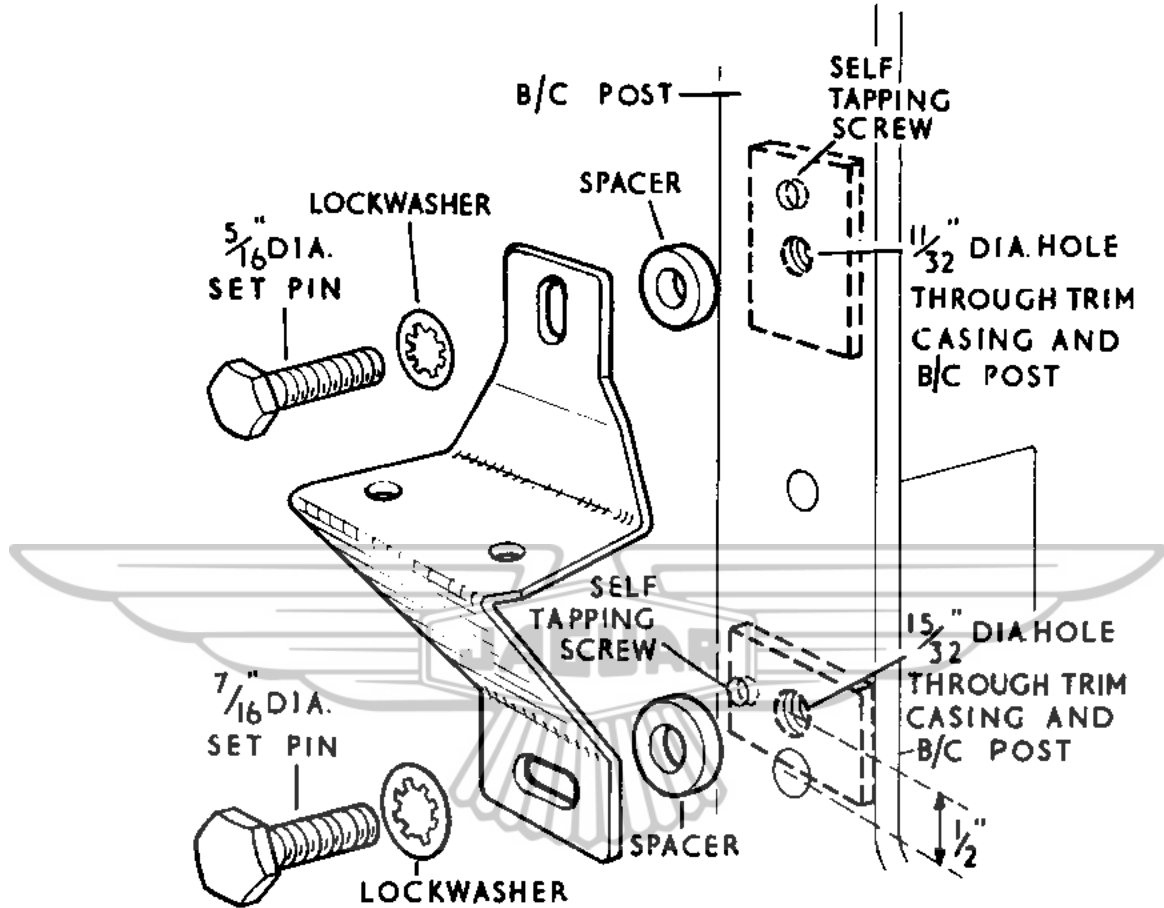

FIG.2 MOUNTING POINTS A₁ & A₂

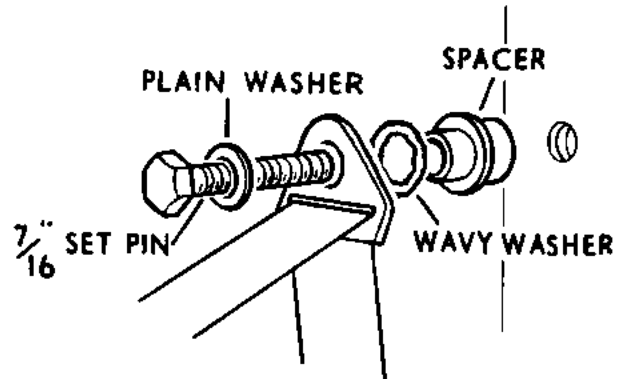

FIG.3 MOUNTING POINT B

Number N.38

Section Body and Exhaust System

Page 1 of 1

Date December, 1966

FRONT WINGS

2.4/3.4/3.8 Litre Mark 2

3.4/3.8 'S' Type

When present stocks are exhausted, a revised service condition of Front Wings for Mark 2 and 'S' Type cars will be supplied by Jaguar Spares Division.

The new condition will consist of three separate items as follows:-

Mk. 2 Models (R.H. front wing assembly - Part No. 11141
(L.H. front wing assembly - Part No. 11142
(Panel - joining front wings at top - Part No. 11143

"S" Type (R.H. front wing assembly - Part No. 11144
(L.H. front wing assembly - Part No. 11145
(Panel - joining front wings at top - Part No. 11146

These items must be ordered individually.

Care must be taken before welding the top panel that the bonnet lock control is correctly positioned.

The new chassis number is stamped on the panel. This should be re-stamped when a new panel is fitted.

Spares Bulletin P.174 refers.

Number N.39
Section Body and Exhaust

Page 1 of 1
Date December, 1966

EXHAUST SYSTEM

Models affected

2.4 Litre Mark 2

Commencing chassis numbers

<u>R.H.D.</u>	<u>L.H.D.</u>
120291	128054

Commencing at the above chassis numbers the exhaust tail pipe installation was revised.

The tail pipe now incorporates a separate chrome plated portion, and the use of a square rubber/steel bonded mounting is discontinued in favour of a circular rubber mounting identical with that already fitted on 3.4/3.8 litre Mark 2 cars.

The new parts introduced are interchangeable, in Car Sets only, with the previous type.

Spares Bulletin M.58 refers.

Number N.43
Section Body and Exhaust

Sheet 1 of 1
Date March, 1967

This Service Bulletin supersedes the original issue of Service Bulletin N.36, dated April, 1966.

PAINT COLOURS
(All Models)

The following list gives the paint colour range being used in current production.

The reference numbers quoted against each paint colour is for Quick-Air drying enamel used for local repairs to the paintwork following accident damage.

REPAIR ENAMEL

COLOUR	SUPPLIER	REF. NO.	THINNERS NO.
OPALESCENT SILVER BLUE	I.C.I.	PO31-2640	851/222 I.C.I.
OPALESCENT SILVER GREY	I.C.I.	PO31-2639	851/222 I.C.I.
PRIMROSE	I.C.I.	PO30-3297	851/222 I.C.I.
DARK BLUE	I.C.I.	PO30-4647	851/222 I.C.I.
SHERWOOD GREEN (Special order only)	BERGER	4D1824	851/222 BERGER
CARMEN RED	BERGER	4D1897	851/222 BERGER
WILLOW GREEN	BERGER	4D1888	851/222 BERGER
OPALESCENT MAROON	P.J.	CLR7	851/222 P.J.
OLD ENGLISH WHITE	P.J.	C768X0110	851/222 P.J.
WARWICK GREY	P.J.	765F2615	851/222 P.J.
OPALESCENT (NEW LIGHT) MAROON	P.J.	CLR.23	851/222 P.J.
BLACK	G.I.P.	GL.5030/B	851/222 G.I.P.
OPALESCENT DARK GREEN	G.I.P.	GL.24734/M	851/222 G.I.P.
OPALESCENT GOLDEN SAND	G.I.P.	GL.24337/M	851/222 G.I.P.
HONEY BEIGE	G.I.P.	GL.26632/V	851/222 G.I.P.
BRITISH RACING GREEN.	G.I.P.	24400	

Number N.44
Section Body and Exhaust System

Sheet 1 of 1
Date July, 1967

BOOT LID LOCK

Models affected

2.4 litre Mark 2
3.4 litre Mark 2
3.8 litre Mark 2

Commencing Chassis Numbers

R.H.D.	L.H.D.
121267	128280
171582	181311
235304	224709

Commencing at the above chassis numbers an improved boot lid lock was fitted.

The lock incorporated a revised cam to prevent the boot lid from opening when on the road.

The lock is fully interchangeable with the previous type and will not be subject to a change of Part Number.

If complaints are received of the boot lid opening when the car is on the road, it is recommended that the new lock is fitted.

Future supplies of the lock will be to the new condition.

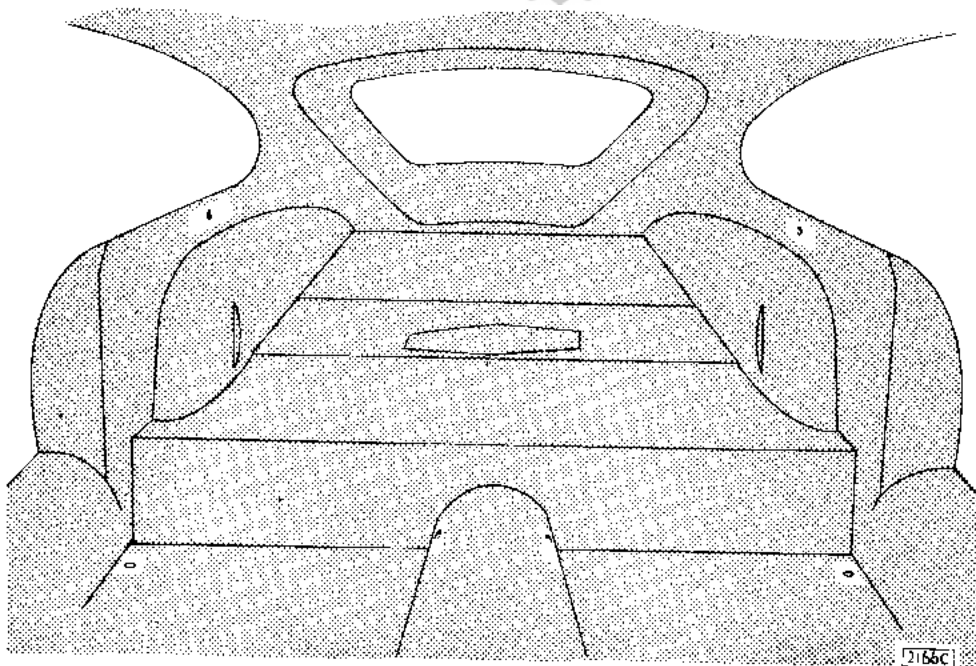
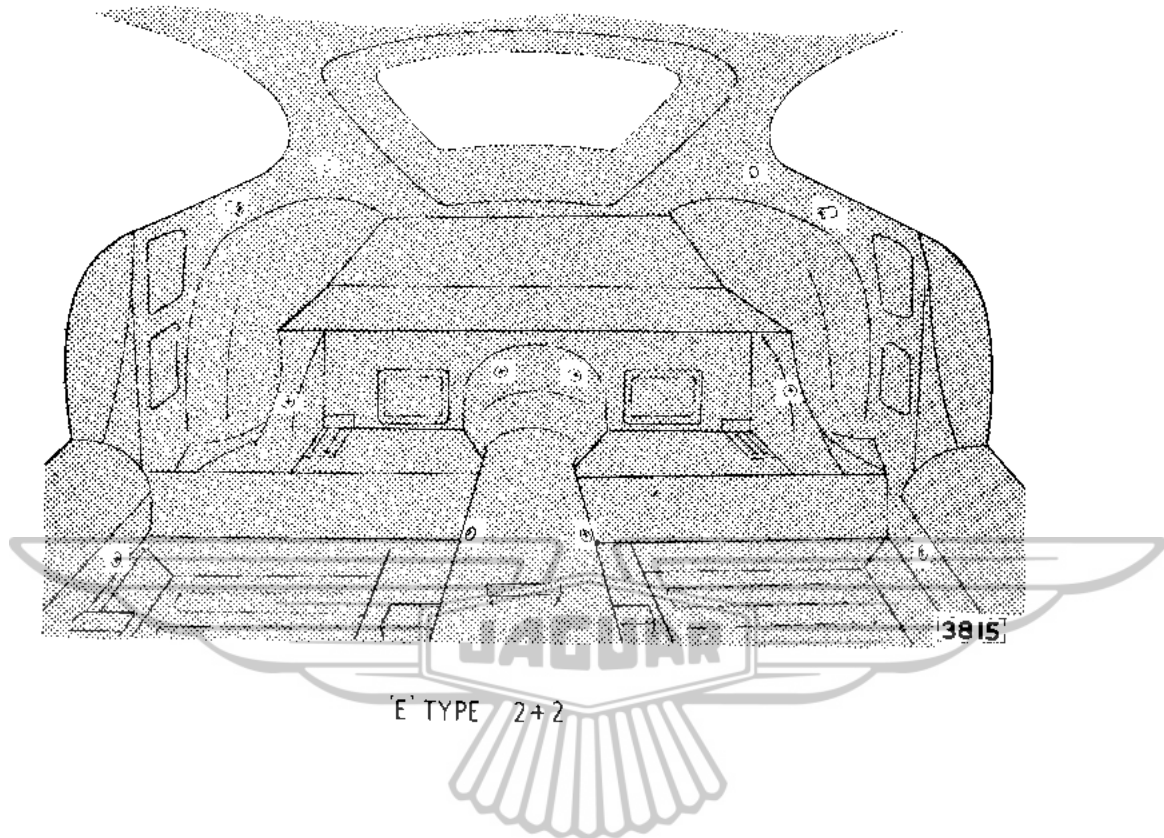

'E' TYPE FIXED HEAD COUPE

Number N.47
Section Body and Exhaust

Page 1 of 1
Date January, 1968

PAINT COLOURS
(All Models)

This bulletin is issued to clarify the information given in Bulletin N.36 referring to Paint Colours (Quick Air-Drying Enamel).

The Reference Number quoted is the Suppliers Number which appears on the tin. In some instances the number may be preceded by the letters G, Q, or P, which denote gallons, quarts, or pints.

The Thinners Number as stated is the Suppliers Number, a common reference being used.

The Paint Suppliers are as follows:-

I.C.I. - Imperial Chemical Industries (Belco)
G.I.P. - General and Industrial Paints (Glassco)
P.J. - Pinchin Johnson
BERGER - Berger

Two additional Paints should be added to the range quoted in Bulletin N.36 as follows:-

	<u>SUPPLIER</u>	<u>REF: NO.</u>	<u>THINNERS</u>	
BRITISH RACING GREEN	G.I.P.	GL24400	851/222	G.I.P.
HONEY BEIGE	G.I.P.	GL26632V	851/222	G.I.P.

Note: The prefix letter for G.I.P. paints in Bulletin N.36 should be GL and not C.L. or L.C. Please mark your copy of N.36 accordingly.

Number N. 83
 Section Body and Exhaust
 Page 1 of 2
 Date July, 1971.

PAINT REFERENCE NUMBERS

For those Distributors, Dealers and Accident Repair Specialists using Low Bake Ovens. This Bulletin has been issued in order to clarify the situation regarding paint colours and reference numbers.

<u>Colour</u>	<u>Supplier</u>	<u>Low-Bake Ref. No.</u>	<u>Air-Drying Ref. No.</u>
Black	G. I. P.	LSC. 5030	GL. 5030
Sable	G. I. P.	LSC. 25734	GL. 25734
Ascot Fawn	G. I. P.	LSC. 26896	GL. 26896
Regency Red	G. I. P.	LSC. 27420	GL. 27420
British Racing Green (Up to October 1970)	G. I. P.	LSC. 24400	GL. 24400
British Racing Green (October 1970 onwards)	G. I. P.	LSC. 28461	GL. 28461
Special Police White	G. I. P.	LSC. 24048	GL. 24048
Willow Green	Berger	404-2017	404-1888
Signal Red	Berger	504-0020	416-0021
Cream (Up to October 1970)	Pinchin Johnson (Jaguar reference J915)	0765X0010	0765X0015 (Jaguar reference J863)
Old English White (October 1970 onwards)	Pinchin Johnson	3765X0010	765X0011
Warwick Grey	Pinchin Johnson (Jaguar reference J931)	0765F 2613	6170X 6380 (Jaguar reference J932)
Light Blue	I. C. I. (Jaguar reference J1081)	M072-4385	M070-4385 (Jaguar reference J1082)
Pale Primrose	I. C. I. (Jaguar reference J1075)	M087-6974	M070-6074 (Jaguar reference J1076)
Dark Blue	I. C. I. (Jaguar reference J1079)	M072-4647	M070-4647 (Jaguar reference J1080)
Light Silver (metallic)	I. C. I. (Jaguar reference J1083)	M079-3308	PO31-3308 (Jaguar reference J1084)

continued

Low Bake paint can only be obtained from the paint manufacturers or from recognised outlets. JAGUAR CARS LIMITED do not supply Low Bake Paint.

Air Drying paint is obtainable from Spares Division, Jaguar Cars Limited, in Gallon, Quart or Pint containers as well as Touch-up size. When ordering, the reference number should be prefixed with the initial letter of the container size as indicated below.

G = Gallon	Q = Quart
P = Pint	T = Touch-up

NOTE:

Cars fitted with Air Conditioning equipment must NOT be subjected to Low Bake process unless the system has been depressurized by a refrigeration engineer.



Number	N.84
Section	Body
Page	1 of 2
Date	November, 1971.

BONNET MASCOT

Models affected

2.4 / 3.4 litre Mark 1
2.4 / 3.4 / 3.8 litre Mark 2
3.4 / 3.8 litre 'S' type

Difficulties in manufacturing Bonnet Mascot BD.10954 have resulted in it being withdrawn and supplies are no longer available. Orders for replacements for the above cars will therefore be executed by Jaguar Spares Division supplying an alternative Bonnet Mascot BD.29644 which varies from the original by the positions of the mounting studs. Instructions for the installation of the new Mascot are therefore detailed below.

INSTALLATION INSTRUCTIONS FOR BONNET MASCOT BD.29644

If the original Bonnet Mascot, part number BD.10954, is replaced by Mascot part number BD.29644, the following instructions should be carefully followed:-

1. Remove original Mascot from bonnet
2. Remove front and rear portion of bonnet centre beading
3. Retouch paintwork (if necessary) where bonnet is affected by contact with Mascot or chrome beading.
4. Lightly mark centre line through existing fixing holes, extending line forward by 2 in. (50 mm.).
5. Drill 3/16 in. (4.8 mm.) hole 'A' on centre line, 1 3/8 in. (35 mm.) to rear of front Mascot fixing hole. Locate new Mascot in holes
6. Place rear chrome bead in position, mark against rear of new Mascot base. Remove chrome bead and carefully cut to length. Clean up end of bead.
7. Place front chrome bead in position, mark against front of new Mascot base. Remove chrome bead and carefully cut to length. Clean up end of bead.

Number	N.84
Section	Body
Page	1 of 2
Date	November, 1971.

BONNET MASCOT

Models affected

2.4 / 3.4 litre Mark 1
2.4 / 3.4 / 3.8 litre Mark 2
3.4 / 3.8 litre 'S' type

Difficulties in manufacturing Bonnet Mascot BD.10954 have resulted in it being withdrawn and supplies are no longer available. Orders for replacements for the above cars will therefore be executed by Jaguar Spares Division supplying an alternative Bonnet Mascot BD.29644 which varies from the original by the positions of the mounting studs. Instructions for the installation of the new Mascot are therefore detailed below.

INSTALLATION INSTRUCTIONS FOR BONNET MASCOT BD.29644

If the original Bonnet Mascot, part number BD.10954, is replaced by Mascot part number BD.29644, the following instructions should be carefully followed:-

1. Remove original Mascot from bonnet
2. Remove front and rear portion of bonnet centre beading
3. Retouch paintwork (if necessary) where bonnet is affected by contact with Mascot or chrome beading.
4. Lightly mark centre line through existing fixing holes, extending line forward by 2 in. (50 mm.).
5. Drill 3/16 in. (4.8 mm.) hole 'A' on centre line, 1 3/8 in. (35 mm.) to rear of front Mascot fixing hole. Locate new Mascot in holes
6. Place rear chrome bead in position, mark against rear of new Mascot base. Remove chrome bead and carefully cut to length. Clean up end of bead.
7. Place front chrome bead in position, mark against front of new Mascot base. Remove chrome bead and carefully cut to length. Clean up end of bead.