

Parts Technical Information

Parts Technical Services
 Telephone No. (0) 203 307767
 Facsimile No. (0) 203 305625

DATE: March 1992

P.T.I.: 153

FICHR: RTC 9910

MODELS: Coupe & Convertible

GROUP: Chassis, Subframes, Bodyshell, Fittings

SUBJECT: Door locks

REASON FOR CHANGE:

New Door locks have been introduced onto XJS Facelift. The Part Numbers for these items are as follows:-

BEC 17545	Lockset doors Coupe	1
BEC 17544	Lockset doors, gearbox and trunk Convertible only	1

OUTSIDE DOOR HANDLE ASSY

BEC 18418	RH	1
BEC 18419	LH	1
BEC 9356	Clamp door handle-RH	1
BEC 9357	Clamp door handle-LH	1
BEC 8690	Gasket handle to door-RH	1
BEC 8691	Gasket handle to door-LH	1
ADU 3476 J	Clip linkage	
BDC 7616	Bush linkage	
FN 105045 J	Flange nut	

BLANK KEY

JLM 1950	Key	1
JLM 1948	Torch key	1
BCC 9959	Cassette (battery and bulb)	1

REPAIR KIT-LOCKING BARREL

JLM 10791	RH	
JLM 10790	LH	
BEC 8984	Mounting bracket-RH	1
BEC 8985	Mounting bracket-LH	1
BEC 15577	Bellcrank	2
BEC 12378	Linkage-bellcrank to handle-RH	1
BEC 12379	Linkage-bellcrank to handle-LH	1
BEC 12380	Linkage-bellcrank to latch-RH	1
BEC 12381	Linkage-bellcrank to latch-LH	1
BEC 16966	Linkage lock to latch-RH	1
BEC 16967	Linkage lock to latch-LH	1
BD 44650	Bush and clip assy	4
BD 45018	Pivot adjustable linkage	2

LOCK AND ACTUATOR ASSY

BEC 4798	RH	
BEC 4799	LH	

Parts Technical Information

DATE: July 1994

P.T.I.: 169

FICHE: RTC 9910

MODELS: XJS - CONVERTIBLE

SUBJECT: Interior Rear View Mirrors

From (V)190528 two types of Interior Rear View Mirror have been fitted to Convertible models. The information concerning these mirrors is as follows:-

BEC 24923 - From (V)190528 and up to (V)192500

BEC 24924 - From (V)192501

The Fiche will reflect this for the next issue.

PARTS OPERATIONS



Parts Technical Information

Parts Technical Services
Facsimile No. (0)1203 404036

DATE: December 1994

P.T.I. : 178

FICHE: RTC 9910 FH
RTC 9918 FF
RTC 9922 FC

MODELS: XJS Range
Jaguar Saloon Range
The New XJ Series

SUBJECT: JLM 11649 - Cylinder Head Gasket Set

Gasket Sets bought prior to 12/12/94 may incorrectly contain EBC 3531 - Seal-Valve Stem.

These are not suitable for 7 mm diameter Valve Stems and should be substituted with EBC 3956 (Quantity 24).

VS6043

Parts Technical Information

Parts Technical Services
Telephone No. (0) 203 307767
Facsimile No. (0) 203 305625

DATE: December 1991

P.T.I.: 152

MODELS: XJS From (V)179737

FICHE: RTC 9910

GROUP: Chassis, Subframes, Bodyshell, Fittings

SUBJECT: Front Window Regulators

REASON FOR CHANGE:

The Parts Microfiche for the XJS Range (RTC 9910) contains incorrect information for Window Regulator motors.

The Fiche should read:-

BDC 8222	Regulator RH
JLM 10581	Motor RH

BDC 8223	Regulator LH
JLM 10580	Motor LH

The next issue of the Microfiche RTC 9910 FB will be correct.

Parts Technical Information

Parts Technical Services
Telephone No. (0) 203 307767
Facsimile No. (0) 203 305625

DATE: March 1992

P.T.I.: 153

FICHR: RTC 9910

MODELS: Coupe & Convertible

GROUP: Chassis, Subframes, Bodyshell, Fittings

SUBJECT: Door locks

REASON FOR CHANGE:

New Door locks have been introduced onto XJS Facelift. The Part Numbers for these items are as follows:-

BEC 17545	Lockset doors Coupe	1
BEC 17544	Lockset doors, gearbox and trunk Convertible only	1

OUTSIDE DOOR HANDLE ASSY

BEC 18418	RH	1
BEC 18419	LH	1
BEC 9356	Clamp door handle-RH	1
BEC 9357	Clamp door handle-LH	1
BEC 8690	Gasket handle to door-RH	1
BEC 8691	Gasket handle to door-LH	1
ADU 3476 J	Clip linkage	
BDC 7616	Bush linkage	
FN 105045 J	Flange nut	

BLANK KEY

JLM 1950	Key	1
JLM 1948	Torch key	1
BCC 9959	Cassette (battery and bulb)	1

REPAIR KIT-LOCKING BARREL

JLM 10791	RH	
JLM 10790	LH	
BEC 8984	Mounting bracket-RH	1
BEC 8985	Mounting bracket-LH	1
BEC 15577	Bellcrank	2
BEC 12378	Linkage-bellcrank to handle-RH	1
BEC 12379	Linkage-bellcrank to handle-LH	1
BEC 12380	Linkage-bellcrank to latch-RH	1
BEC 12381	Linkage-bellcrank to latch-LH	1
BEC 16966	Linkage lock to latch-RH	1
BEC 16967	Linkage lock to latch-LH	1
BD 44650	Bush and clip assy	4
BD 45018	Pivot adjustable linkage	2

LOCK AND ACTUATOR ASSY

BEC 4798	RH	
BEC 4799	LH	

Parts Technical Information

Parts Technical Services
Telephone No. (0) 203 307767
Facsimile No. (0) 203 305625

DATE: May 1992

P.T.I.: 154 Iss. 2

MODELS: XJ40 and XJS

FICHE: RTC 9893
RTC 9910

GROUP: Chassis, Subframes, Bodyshell, Fittings

SUBJECT: Reinforcement-Handle Aperture Door

REASON FOR CHANGE:

REF:- DOOR ASSEMBLIES & OUTER PANELS (USING DOOR LOCKS WITH "SPINDLE" TYPE KEYS

This is a second issue of P.T.I. 154 (April 1992) which has been amended to remove any ambiguity in the meaning of the original P.T.I. Please remove your copy of the first issue from your files and replace with this issue.

Replacement Door Assemblies and Outer Door Panels are to be supplied without the reinforcement for the Door Handle aperture. The "Cathodic" paint process for electrocoat primer application, requires a high paint curing temperature. This temperature adversely affects the adhesive which is used to secure the reinforcing strip to the Outer Door Panel.

When ordering a Door Assembly or Outer Door Panel the Steel Reinforcing ring- CAP 4036 will also be required. CAP 4036 should be fitted using an approved body sealant to the Door Panel.

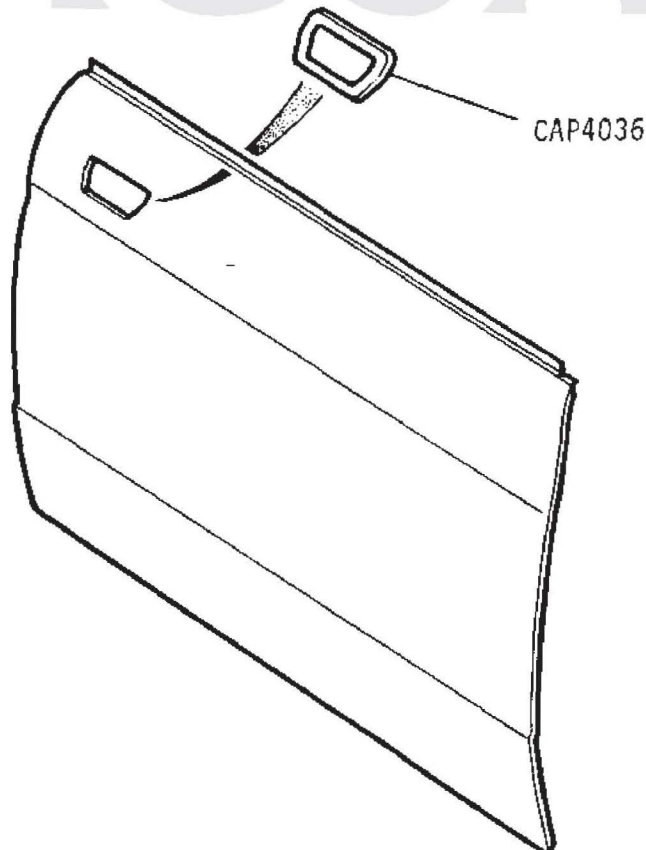

Parts Technical Information

Parts Technical Services
Telephone No. (0) 203 307767
Facsimile No. (0) 203 305625

DATE: March 1992

P.T.I.: 153

FICHR: RTC 9910

MODELS: Coupe & Convertible

GROUP: Chassis, Subframes, Bodyshell, Fittings

SUBJECT: Door locks

REASON FOR CHANGE:

New Door locks have been introduced onto XJS Facelift. The Part Numbers for these items are as follows:-

BEC 17545	Lockset doors Coupe	1
BEC 17544	Lockset doors, gearbox and trunk Convertible only	1

OUTSIDE DOOR HANDLE ASSY

BEC 18418	RH	1
BEC 18419	LH	1
BEC 9356	Clamp door handle-RH	1
BEC 9357	Clamp door handle-LH	1
BEC 8690	Gasket handle to door-RH	1
BEC 8691	Gasket handle to door-LH	1
ADU 3476 J	Clip linkage	
BDC 7616	Bush linkage	
FN 105045 J	Flange nut	

BLANK KEY

JLM 1950	Key	1
JLM 1948	Torch key	1
BCC 9959	Cassette (battery and bulb)	1

REPAIR KIT-LOCKING BARREL

JLM 10791	RH	
JLM 10790	LH	
BEC 8984	Mounting bracket-RH	1
BEC 8985	Mounting bracket-LH	1
BEC 15577	Bellcrank	2
BEC 12378	Linkage-bellcrank to handle-RH	1
BEC 12379	Linkage-bellcrank to handle-LH	1
BEC 12380	Linkage-bellcrank to latch-RH	1
BEC 12381	Linkage-bellcrank to latch-LH	1
BEC 16966	Linkage lock to latch-RH	1
BEC 16967	Linkage lock to latch-LH	1
BD 44650	Bush and clip assy	4
BD 45018	Pivot adjustable linkage	2

LOCK AND ACTUATOR ASSY

BEC 4798	RH	
BEC 4799	LH	

Parts Technical Information

Parts Technical Services
Telephone No. (0) 203 307767
Facsimile No. (0) 203 305625

DATE: November 1992

P.T.I.: 158 ¹⁵⁹ ~~158~~

MODEL: XJS (From (V) 139052 up to (V) 179736)

FICHE: RTC 9900

SUBJECT: Front Wings

PART NUMBER BHC 1810 RH
 BHC 1811 LH

Due to a change in the manufacturing process, future supplies of BHC 1810 and BHC 1811 will have excess metal in the areas shown below.

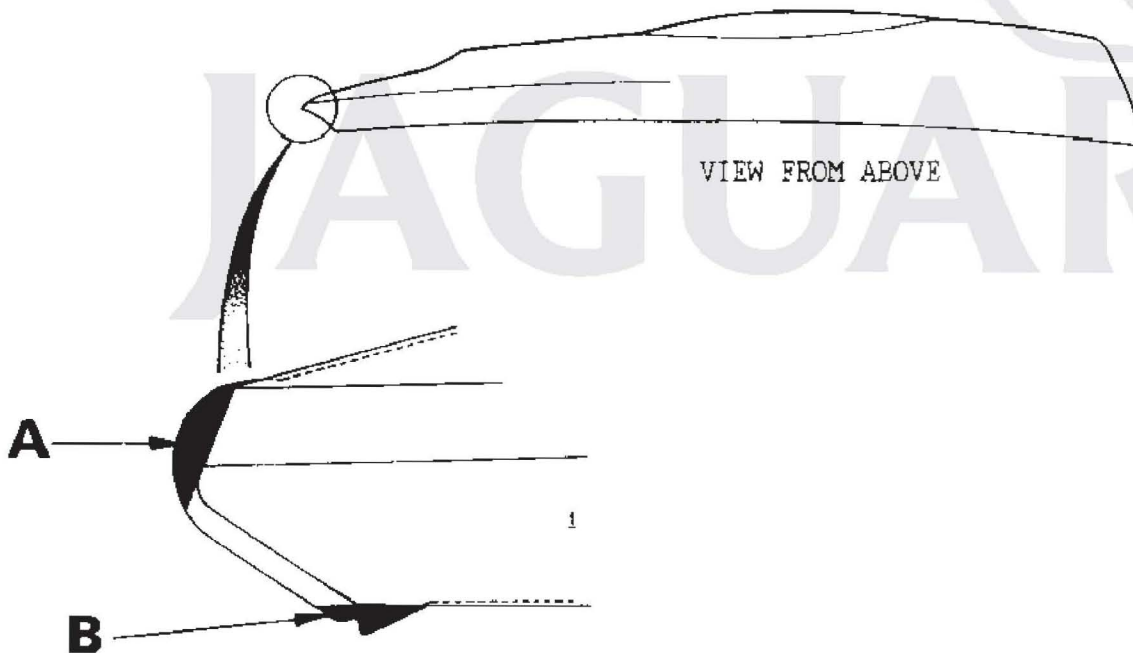

Metal should be removed from areas A & B to match the profile of existing body panels.

Dress and repaint affected areas to approved Jaguar standard.

Parts Technical Information

Parts Technical Services
Telephone No. (0) 203 307767
Facsimile No. (0) 203 305625

DATE: August 1992

P.T.I.: 156

MODELS: XJS

FICHE: RTC 9878

GROUP: Chassis, Subframes, Bodyshell, Fittings

RTC 9888

RTC 9900

RTC 9910

SUBJECT: Jaguar XJS front window regulator assemblies

REASON FOR CHANGE:

At V.I.N. 184117 new front window motor/regulator assemblies were introduced and the previous type of motor/assembly will no longer be available.

The new assemblies, or motors within those assemblies can, together with certain other components be used to replace all XJS front window regulator assemblies prior to V.I.N. 184117.

Please see on the following pages for supersession details:

FROM:- CHRIS SMITH
~~PARTS OPERATIONS~~

COUPE/CABRIOLET

EXISTING MOTOR/REGULATOR ASSY	MOTOR		REPLACEMENT PART(S) REQUIRED	QTY	CHANGE POINT
BEC 22008 RH	JLM 11002 RH		BEC 22008 JLM 11002	1 1	{ { FROM (V)184117
BEC 22009 LH	JLM 11003 LH		BEC 22009 JLM 11003	1 1	{ {
BDC 8222 RH	JLM 10581 RH		BEC 22008 JLM 11002	1 1	{ { FROM (V)179737
BDC 8223 LH	JLM 10580 LH		BEC 22009 JLM 11003	1 1	{ UP TO (V)184116 {
BEC 10006 RH	JLM 10542 RH	{ {	JLM 11018 (Regulator only) JLM 11002 DBC 11503	1 1 1	{ { { FROM (V)174362
BEC 10007 LH	JLM 10543 LH	{ {	JLM 11019 (Regulator only) JLM 11003 DBC 11503	1 1 1	{ UP TO (V)179736 { {
BCC 5774	JLM 1495	{ { { { {	JLM 11018 JLM 11002 DBC 11503 JLM 11018 JLM 11002 DBC 11503	1 1 1 1 1 1	{ { { { { { ALL XJS { UP TO (V)174361
BCC 5775	JLM 1496	{ { { { {	JLM 11019 JLM 11003 DBC 11503 JLM 11019 JLM 11003 DBC 11503	1 1 1 1 1 1	{ { { { { {

SEE LIST (A) FOR REPLACEMENT PART DESCRIPTION

CONVERTIBLE

EXISTING MOTOR/REGULATOR ASSY	MOTOR		REPLACEMENT PART(S) REQUIRED	QTY	CHANGE POINT
BEC 22008 RH	JLM 11002 RH		BEC 22008 JLM 11002	1 1	{ { FROM (V)184117
BEC 22009 LH	JLM 11003 LH		BEC 22009 JLM 11003	1 1	{ {
BDC 8222 RH	JLM 10581 RH		BEC 22008 JLM 11002	1 1	{ { FROM (V)179737
BDC 8223 LH	JLM 10580 LH		BEC 22009 JLM 11003	1 1	{ { UP TO (V)184116
BDC 5078 RH		{	JLM 10578	1	{
		{	DBC 11503	1	{
		{	BD 48949/3	4	{
	JLM 1495 RH	{	JLM 10578	1	{
		{	DBC 11503	1	{
		{	BD 48949/3	4	{
					{ UP TO (V)179736
BDC 5079 LH		{	JLM 10579	1	{
		{	DBC 11503	1	{
		{	BD 48949/3	4	{
	JLM 1496 LH	{	JLM 10579	1	{
		{	DBC 11503	1	{
		{	BD 48949/3	4	{

SEE LIST (A) FOR REPLACEMENT PART DESCRIPTION

LIST (A)

REPLACEMENT PARTS

BD 48949/3	Screw-fixing
BEC 22008	Motor/Regulator assembly RH
BEC 22009	Motor/Regulator assembly LH
DBC 11503	Adaptor link lead
JLM 10578	Motor/Regulator assembly RH
JLM 10579	Motor/Regulator assembly LH
JLM 11002	Motor Pack RH
JLM 11003	Motor Pack LH
JLM 11018	Regulator mechanism RH
JLM 11019	Regulator mechanism LH

