

Parts Technical Information

Parts Technical Services
Telephone No. (0) 203 307767
Facsimile No. (0) 203 305625

DATE: January 1993

P.T.I.: 161

MODELS: XJS range
XJ6 range

Series III 5.3 Litre

FICHE: RTC 9910
RTC 9893 &
RTC 9918
RTC 9898

SUBJECT: Steering Racks

REASON FOR CHANGE:

Page 1 on P.T.I. No. 160 issue 2 showed an incorrect Part Number **JZS 100019** for the Washer. The correct Part Number is **JZW 100019** and is shown below.

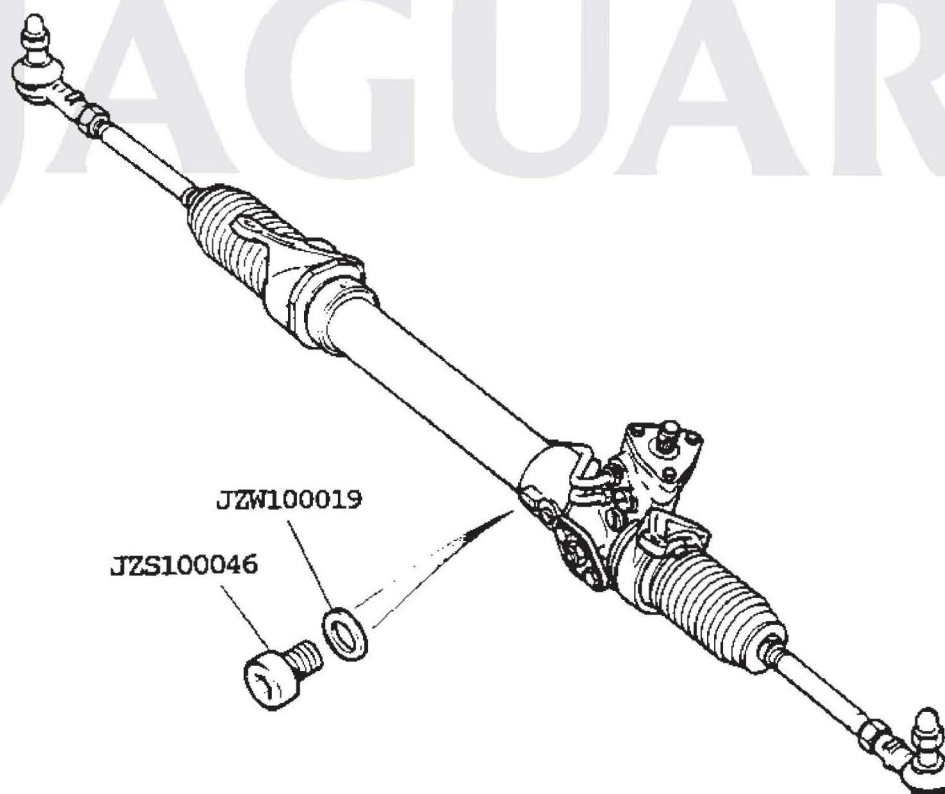

Parts Technical Information

Parts Technical Services
Telephone No. (0) 203 402121
Facsimile No. (0) 203 404036

DATE: May 1993

P.T.I.: 165

MODELS: Saloon Range
XJS Range

FICHE: RTC 9918
RTC 9910

SUBJECT: Radio/Cassette Players

REASON FOR CHANGE:

Please note the following Radio Cassette Players were introduced at the VIN Numbers shown below and are not interchangeable with Radio Cassette fitted to vehicles prior to these VIN Numbers. This is due to speaker incompatibility on the Saloon Range and the incorporation of the telephone mute system on the XJS Range.

SALOON RANGE

DBC 11303	Weather Band (WB)	{
DBC 11304	Radio Data Service (RDS)-Jaguar	{
DBC 11305	Loud (LD)	{ From (V)667829
DBC 11306	Traffic-Japan only	{
DBC 11307	Radio Data Service (RDS)-Daimler	{

XJS RANGE

DAC 7613	Radio Data Service (RDS)	From (V)186981
DAC 7614	Weather Band (WB)	From (V)187585
DAC 7615	Traffic-Japan only	From (V)188105
DAC 7616	Loud (LD)	From (V)186981

Parts Technical Information

Parts Technical Services
Telephone No. (0) 203 307767
Facsimile No. (0) 203 305625

DATE: January 1993

P.T.I.: 160 iss. 2

MODELS: XJS range
XJ6 range

Series III 5.3 Litre

FICHE: RTC 9910
RTC 9893 &
RTC 9918
RTC 9898

SUBJECT: Steering Racks

REASON FOR CHANGE:

A recent change of Steering Rack manufacturer has taken place. The new Racks are visually different from the old, but are fully interchangeable.

The new type parts will be supplied when stocks of the old are exhausted as per the charts on the following page; any original equipment part number not mentioned on the following lists will continue to be supplied until further notice.

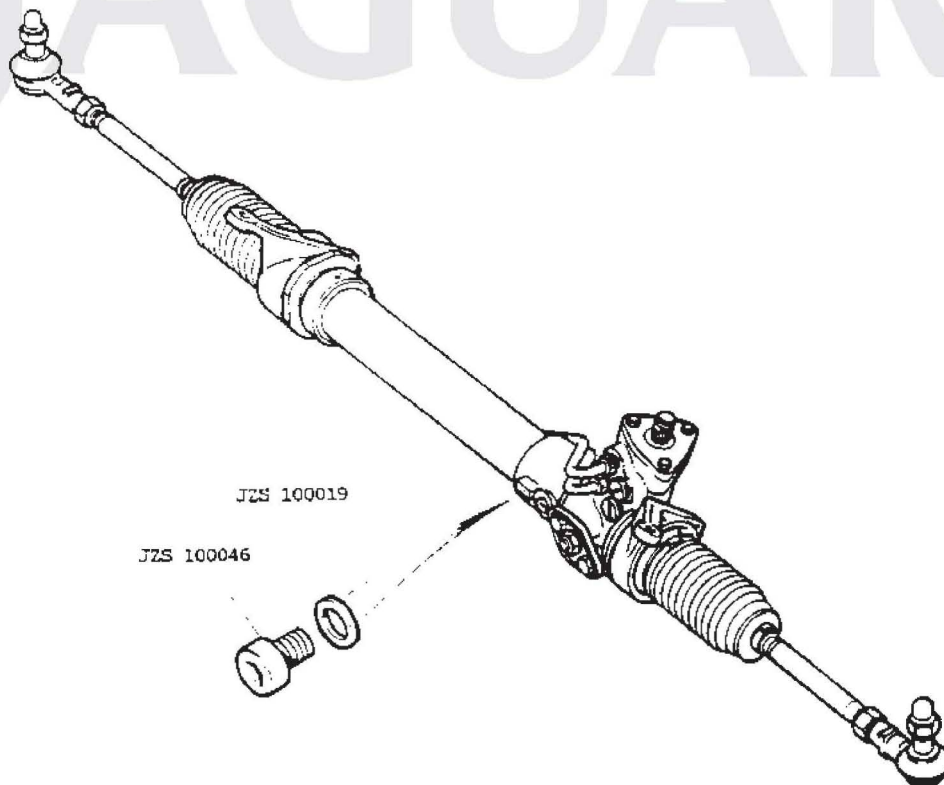

vs 5520

402862

XJS/SERIES III

VEHICLE/VARIANT	RACK PART NUMBERS	
	ORIGINAL	NEW *
XJS (AJ6) RHD	CCC 5668	CCC 6014
Coupe Std & Conv LHD	CCC 5669	CCC 6015
XJS (AJ6) RHD	CCC 5666	CCC 6012
Sportspack susp LHD	CCC 5667	CCC 6013
Series III (V12) RHD	CCC 5664	CCC 6014
LHD	CCC 5665	CCC 6015
XJS (V12) RHD	CCC 5662	CCC 6014
Coupe Std & Conv LHD	CCC 5663	CCC 6015
XJS (V12) RHD	CCC 5660	CCC 6012
Sportspack susp LHD	CCC 5661	CCC 6013

XJ40

VEHICLE/VARIANT	RACK PART NUMBERS			
	PRE 93 MY		93 MY	
	ORIGINAL	NEW *	ORIGINAL	NEW *
XJ40 Std RHD	CCC 5650	CCC 6020	CCC 5188	CCC 6006
LHD	CCC 5651	CCC 6021	CCC 5189	CCC 6007
XJ40 S/Pack RHD	CCC 5652	CCC 6022	CCC 5190	CCC 6008
LHD	CCC 5653	CCC 6023	CCC 5191	CCC 6009

* Add Suffix N (New) or E (Exchange available shortly) to order.

N.B. When ordering the above range of Steering Racks the following additional parts will be required.

JZS 100046 x 1 Screw
JZW 100019 x 1 Washer

To replace Centralising tool supplied with Rack.

CCC. 6012 IF USED FOR CCC. 5662
 USE:- CBC. 9148 - HOSE
 CBC. 9404 - HOSE
 C. 38894 + C. 3169/5
 CCC

Parts Technical Information

Parts Technical Services
Telephone No. (0) 203 307767
Facsimile No. (0) 203 305625

DATE: November 1991

P.T.I.: 147

MODELS: XJS Range from (V)179737

FICHE: RTC 9910

GROUP: Engine

SUBJECT: Oil Transmitter

REASON FOR CHANGE:

An incorrect Part Number for the Oil Transmitter has been advised in the Fiche.

3 46272 is an incorrect Part Number for this Fiche Application.

3A0 3379 is the correct Part Number.

N.B. 3 46272 is fitted to cars prior to (V)179736.

Parts Technical Information

Parts Technical Services
Telephone No. (0) 203 307767
Facsimile No. (0) 203 305625

DATE: November 1991

P.T.I.: 145

MODELS: XJS Convertible

FICHE: RTC 9900

GROUP: Electrical, Washers, Wipers & Instruments

SUBJECT: Gauge, Fuel Tank Unit

REASON FOR CHANGE:

Suppliers of the original equipment fuel gauge, DAC 6103 are no longer available. A new unit, DAC 10183 is introduced with different positions for the warning light and earth terminals. Detailed below are the two conditions with the respective terminators.

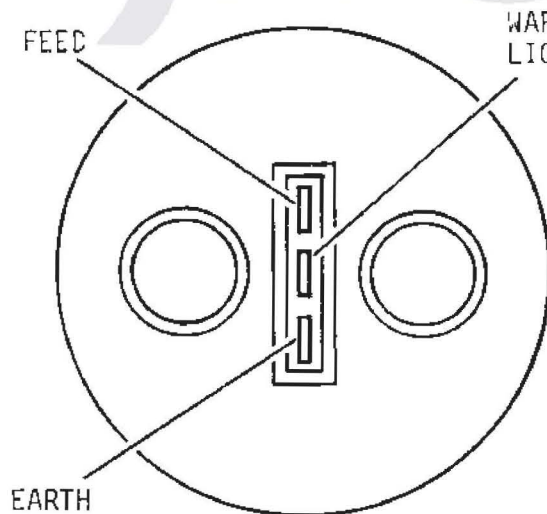

DAC6103

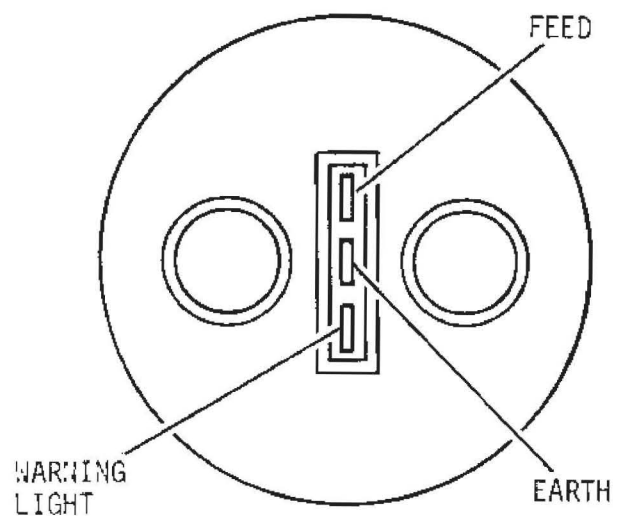

DAC10183