

SUBJECT:- POWER ASSISTED STEERING UNIT.

MODELS AFFECTED.

XJ6 - 2.8 LITRE
XJ6 - 4.2 LITRE
SOVEREIGN - 2.8 LITRE
SOVEREIGN - 4.2 LITRE
SERIES 2 'E' TYPE
SERIES 3 'E' TYPE

A revised Rack Piston Assembly is now being fitted to the above models.

The new Piston will have the same number (12010), but will be supplied as a complete assembly which will include one steel and one plastic ring.

The revised Piston/Rings Assembly is completely interchangeable with the previous Piston.

Piston Ring 12011 will no longer be supplied.

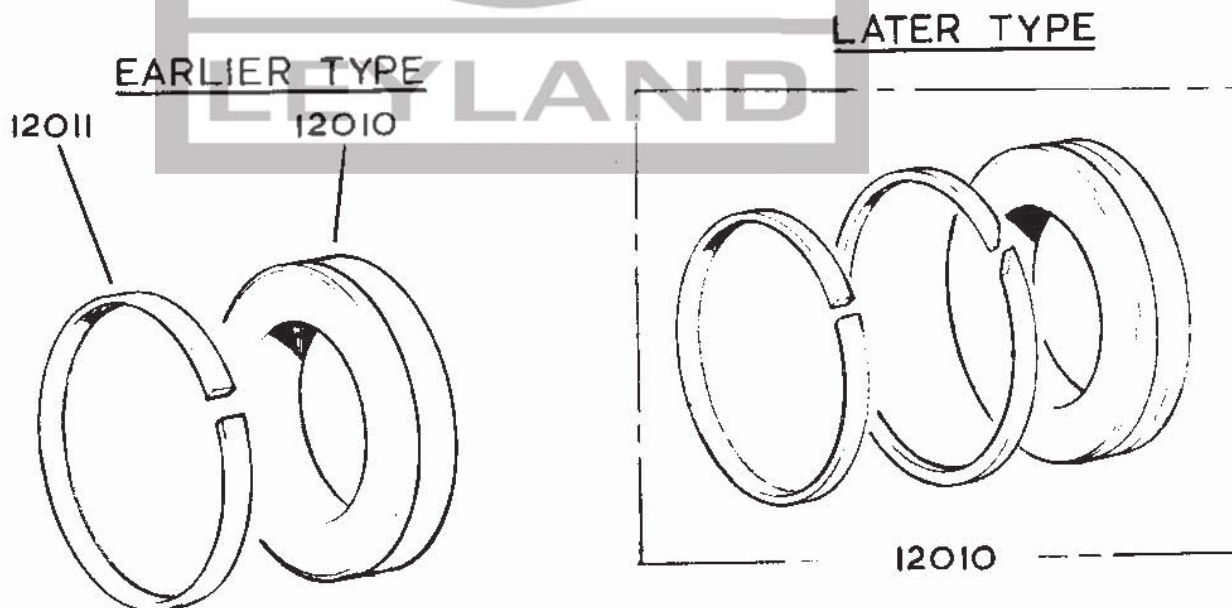

SUBJECT:- P.A.S. ADJUSTER PLATE.

MODELS AFFECTED.

INTRODUCED AT ENGINE NUMBER.

SERIES 3 'E' TYPE OPEN
SERIES 3 'E' TYPE 2+2

78.7785

From the above Engine Number a revised Power Assisted Steering Pump Adjuster Plate was fitted to the above models. Details are as follows :-

<u>Part No.</u>	<u>Description.</u>	<u>Qty.</u>	<u>Remarks.</u>
C.36972	+ Adjuster Plate, for Steering Pump	1	

TRANSPARENCY REFERENCE.

ROW. COLUMN.

JMF.2 - 1ST EDITION

03 13
09 13

